

# MC9S12C Family Device User Guide V01.04

**Covers also**

## MC9S12GC Family

**Original Release Date: 25 JAN 2003  
Revised: 27 JANUARY 2004**

**Motorola, Inc.**

Motorola reserves the right to make changes without further notice to any products herein. Motorola makes no warranty, representation or guarantee regarding the suitability of its products for any particular purpose, nor does Motorola assume any liability arising out of the application or use of any product or circuit, and specifically disclaims any and all liability, including without limitation consequential or incidental damages. "Typical" parameters which may be provided in Motorola data sheets and/or specifications can and do vary in different applications and actual performance may vary over time. All operating parameters, including "Typicals" must be validated for each customer application by customer's technical experts. Motorola does not convey any license under its patent rights nor the rights of others. Motorola products are not designed, intended, or authorized for use as components in systems intended for surgical implant into the body, or other applications intended to support or sustain life, or for any other application in which the failure of the Motorola product could create a situation where personal injury or death may occur. Should Buyer purchase or use Motorola products for any such unintended or unauthorized application, Buyer shall indemnify and hold Motorola and its officers, employees, subsidiaries, affiliates, and distributors harmless against all claims, costs, damages, and expenses, and reasonable attorney fees arising out of, directly or indirectly, any claim of personal injury or death associated with such unintended or unauthorized use, even if such claim alleges that Motorola was negligent regarding the design or manufacture of the part. Motorola and  are registered trademarks of Motorola, Inc. Motorola, Inc. is an Equal Opportunity/Affirmative Action Employer.

©Motorola, Inc., 2002

# Revision History

Version Number	Revision Date	Effective Date	Author	Description of Changes
00.01	25.JAN.03	25.JAN.03		Original Version. Based on C32 user guide version 01.12
00.02	07.FEB.03	07.FEB.03		Enhanced PortK description Part number table revision in preface
00.03	25.FEB.03	25.FEB.03		QFP112 Emulation pinout correction Enhanced part number explanation in preface Reduced pseudo STOP current spec. for C64,C96,C128
00.04	15.APR.03	15.APR.03		Enhanced PortAD signal description Corrected VDDR description in 2.4.2 Revised pin leakage in electrical parameters
00.05	05.MAY.03	05.MAY.03		SPI timing parameter table correction Output drive high value reduced in 3V range PE[4:2] Pull-Up spec out of reset changed 3V Expansion bus timing parameters not tested in production Minimum bus frequency specification increased to 0.25MHz.
00.06	21.MAY.03	21.MAY.03		Parameter classification added to Appendix Table C-2. IOH changed to 4mA for 3V range.
01.00	15.JUL.03	15.JUL.03		LVR level defined.for C32. Run IDD changed for C32. Block guide reference table updated Added PCB layout guide for Pierce oscillator configuration IOL parameter updated in 3.3V range
01.01	12.AUG.03	12.AUG.03		Updated PARTID listing due to C128 ECO revision
01.02	20.NOV.03	20.NOV.03		Changed DOC number and CPU DOC reference number Included separate C32 LVI levels Changed PortM pull up reset state to enabled.
01.03	27.NOV.03	27.NOV.03		Added References to the CAN-less GC-Family No major revision number increment, since silicon functionality is not changed. Added VDDX connection in PCB layout figures 8-1.to 8-6 Added Part ID for 2L45J mask set to Part ID table
01.04	27.JAN.04	27.JAN.04		Table A-4 VDD/VDDPLL min when supplied externally now 2.35V Reference S12FTS128K1 in Preface (was S12FTS128K) Reference to CPU Guide corrected to Version2

# Table of Contents

## Section 1 Introduction

1.1	Overview . . . . .	23
1.2	Features . . . . .	23
1.3	Modes of Operation . . . . .	25
1.4	Block Diagram . . . . .	27
1.5	Device Memory Map. . . . .	28
1.6	Detailed Register Map . . . . .	33
1.7	Part ID Assignments. . . . .	50

## Section 2 Signal Description

2.1	Device Pinout . . . . .	52
2.2	Signal Properties Summary . . . . .	55
2.2.1	Pin Initialization for 48 & 52 Pin LQFP bond-out versions . . . . .	56
2.3	Detailed Signal Descriptions. . . . .	57
2.3.1	EXTAL, XTAL — Oscillator Pins . . . . .	57
2.3.2	RESET — External Reset Pin . . . . .	57
2.3.3	TEST / VPP — Test Pin . . . . .	57
2.3.4	XFC — PLL Loop Filter Pin . . . . .	57
2.3.5	BKGD / TAGHI / MODC — Background Debug, Tag High & Mode Pin . . . . .	58
2.3.6	PA[7:0] / ADDR[15:8] / DATA[15:8] — Port A I/O Pins . . . . .	58
2.3.7	PB[7:0] / ADDR[7:0] / DATA[7:0] — Port B I/O Pins . . . . .	58
2.3.8	PE7 / NOACC / XCLKS — Port E I/O Pin 7. . . . .	58
2.3.9	PE6 / MODB / IPIPE1 — Port E I/O Pin 6 . . . . .	60
2.3.10	PE5 / MODA / IPIPE0 — Port E I/O Pin 5 . . . . .	60
2.3.11	PE4 / ECLK— Port E I/O Pin [4] / E-Clock Output. . . . .	60
2.3.12	PE3 / LSTRB — Port E I/O Pin [3] / Low-Byte Strobe (LSTRB). . . . .	60
2.3.13	PE2 / R/W — Port E I/O Pin [2] / Read/Write. . . . .	60
2.3.14	PE1 / IRQ — Port E input Pin [1] / Maskable Interrupt Pin . . . . .	61
2.3.15	PE0 / XIRQ — Port E input Pin [0] / Non Maskable Interrupt Pin . . . . .	61
2.3.16	PAD[7:0] / AN[7:0] — Port AD I/O Pins [7:0] . . . . .	61
2.3.17	PP[7] / KWP[7] — Port P I/O Pin [7]. . . . .	61
2.3.18	PP[6] / KWP[6]/ROMCTL — Port P I/O Pin [6] . . . . .	61
2.3.19	PP[5:0] / KWP[5:0] / PW[5:0] — Port P I/O Pins [5:0] . . . . .	62

2.3.20	PJ[7:6] / KWJ[7:6] — Port J I/O Pins [7:6]	62
2.3.21	PM5 / SCK — Port M I/O Pin 5	62
2.3.22	PM4 / MOSI — Port M I/O Pin 4	62
2.3.23	PM3 / SS — Port M I/O Pin 3	62
2.3.24	PM2 / MISO — Port M I/O Pin 2	62
2.3.25	PM1 / TXCAN — Port M I/O Pin 1	62
2.3.26	PM0 / RXCAN — Port M I/O Pin 0	62
2.3.27	PS[3:2] — Port S I/O Pins [3:2]	63
2.3.28	PS1 / TXD — Port S I/O Pin 1	63
2.3.29	PS0 / RXD — Port S I/O Pin 0	63
2.3.30	PPT[7:5] / IOC[7:5] — Port T I/O Pins [7:5]	63
2.3.31	PT[4:0] / IOC[4:0] / PW[4:0] — Port T I/O Pins [4:0]	63
2.4	Power Supply Pins	63
2.4.1	VDDX, VSSX — Power & Ground Pins for I/O Drivers	63
2.4.2	VDDR, VSSR — Power & Ground Pins for I/O Drivers & for Internal Voltage Regulator	63
2.4.3	VDD1, VDD2, VSS1, VSS2 — Internal Logic Power Pins	63
2.4.4	VDDA, VSSA — Power Supply Pins for ATD and VREG	64
2.4.5	VRH, VRL — ATD Reference Voltage Input Pins	64
2.4.6	VDDPLL, VSSPLL — Power Supply Pins for PLL	64

## Section 3 System Clock Description

## Section 4 Modes of Operation

4.1	Overview	65
4.2	Chip Configuration Summary	65
4.3	Security	66
4.3.1	Securing the Microcontroller	67
4.3.2	Operation of the Secured Microcontroller	67
4.3.3	Unsecuring the Microcontroller	67
4.4	Low Power Modes	67
4.4.1	Stop	68
4.4.2	Pseudo Stop	68
4.4.3	Wait	68
4.4.4	Run	68

## Section 5 Resets and Interrupts

5.1	Overview	68
5.2	Vectors	68
5.2.1	Vector Table	68
5.3	Resets	69
5.3.1	Reset Summary Table	70
5.3.2	Effects of Reset	70

## Section 6 HCS12 Core Block Description

6.1	Device-specific information	70
6.1.1	PPAGE	70
6.1.2	BDM alternate clock	71
6.1.3	Extended Address Range Emulation Implications	71

## Section 7 Voltage Regulator (VREG) Block Description

7.1	Device-specific information	72
7.1.1	VREGEN	72
7.1.2	VDD1, VDD2, VSS1, VSS2	72

## Section 8 Recommended Printed Circuit Board Layout

## Section 9 Clock Reset Generator (CRG) Block Description

9.1	Device-specific information	79
9.1.1	XCLKS	80

## Section 10 Oscillator (OSC) Block Description

## Section 11 Timer (TIM) Block Description

## Section 12 Analog to Digital Converter (ATD) Block Description

12.1	Device-specific information	80
12.1.1	VRL (voltage reference low)	80

## Section 13 Serial Communications Interface (SCI) Block Description

## Section 14 Serial Peripheral Interface (SPI) Block Description

## Section 15 Flash Block Description

## Section 16 RAM Block Description

## Section 17 Pulse Width Modulator (PWM) Block Description

## Section 18 MSCAN Block Description

## Section 19 Port Integration Module (PIM) Block Description

## Appendix A Electrical Characteristics

A.1	General	83
A.1.1	Parameter Classification	83
A.1.2	Power Supply	83
A.1.3	Pins	84
A.1.4	Current Injection	84
A.1.5	Absolute Maximum Ratings	85
A.1.6	ESD Protection and Latch-up Immunity	86
A.1.7	Operating Conditions	86
A.1.8	Power Dissipation and Thermal Characteristics	87
A.1.9	I/O Characteristics	89
A.1.10	Supply Currents	92

## Appendix B Electrical Specifications

B.1	Voltage Regulator Operating Conditions	95
B.2	Chip Power-up and LVI/LVR graphical explanation	96
B.3	Output Loads	96
B.3.1	Resistive Loads	96
B.3.2	Capacitive Loads	97
B.4	ATD Characteristics	99
B.4.1	ATD Operating Characteristics In 5V Range	99
B.4.2	ATD Operating Characteristics In 3.3V Range	99
B.4.3	Factors influencing accuracy	100
B.4.4	ATD accuracy (5V Range)	102
B.4.5	ATD accuracy (3.3V Range)	102
B.5	NVM, Flash and EEPROM	105
B.5.1	NVM timing	105
B.5.2	NVM Reliability	106

B.6	Reset, Oscillator and PLL. . . . .	109
B.6.1	Startup . . . . .	109
B.6.2	Oscillator . . . . .	110
B.6.3	Phase Locked Loop . . . . .	111
B.7	MSCAN. . . . .	117
B.8	SPI . . . . .	119

## Appendix C Electrical Specifications

C.1	Master Mode. . . . .	119
C.2	Slave Mode. . . . .	121
C.3	External Bus Timing . . . . .	123
C.3.1	General Muxed Bus Timing . . . . .	123

## Appendix D Package Information

D.1	General. . . . .	127
D.2	80-pin QFP package. . . . .	128
D.3	52-pin LQFP package. . . . .	129
D.4	48-pin LQFP package. . . . .	130

## Appendix E Emulation Information

E.1	General. . . . .	131
E.1.1	PK[2:0] / XADDR[16:14]. . . . .	132
E.2	112-pin LQFP package. . . . .	133



# List of Figures

Figure 0-1	Order Part number Coding . . . . .	16
Figure 1-1	MC9S12C-Family Block Diagram . . . . .	27
Figure 1-2	MC9S12C128 and MC9S12GC128 User configurable Memory Map . . . . .	29
Figure 1-3	MC9S12C96 User Configurable Memory Map . . . . .	30
Figure 1-4	MC9S12C64 and MC9S12GC64 User Configurable Memory Map. . . . .	31
Figure 1-5	MC9S12C32 and MC9S12GC32 User Configurable Memory Map. . . . .	32
Figure 1-6	MC9S12GC16 User Configurable Memory Map . . . . .	33
Figure 2-1	Pin Assignments in 80 QFP for MC9S12C-Family . . . . .	52
Figure 2-2	Pin assignments in 52 LQFP for MC9S12C-Family. . . . .	53
Figure 2-3	Pin Assignments in 48 LQFP for MC9S12C-Family . . . . .	54
Figure 2-4	PLL Loop Filter Connections . . . . .	57
Figure 2-5	Colpitts Oscillator Connections (PE7=1) . . . . .	59
Figure 2-6	Pierce Oscillator Connections (PE7=0) . . . . .	59
Figure 2-7	External Clock Connections (PE7=0) . . . . .	59
Figure 3-1	Clock Connections. . . . .	65
Figure 8-1	Recommended PCB Layout (48 LQFP) . . . . .	74
Figure 8-2	Recommended PCB Layout (52 LQFP) . . . . .	75
Figure 8-3	Recommended PCB Layout (80 QFP) . . . . .	76
Figure 8-4	Recommended PCB Layout for 48 LQFP Pierce Oscillator . . . . .	77
Figure 8-5	Recommended PCB Layout for 52 LQFP Pierce Oscillator . . . . .	78
Figure 8-6	Recommended PCB Layout for 80QFP Pierce Oscillator . . . . .	79
Figure B-1	Voltage Regulator - Chip Power-up and Voltage Drops (not scaled) . . . . .	96
Figure B-2	ATD Accuracy Definitions . . . . .	104
Figure B-3	Basic PLL functional diagram . . . . .	112
Figure B-4	Jitter Definitions . . . . .	114
Figure B-5	Maximum bus clock jitter approximation . . . . .	114
Figure C-1	SPI Master Timing (CPHA=0) . . . . .	119
Figure C-2	SPI Master Timing (CPHA=1) . . . . .	120
Figure C-3	SPI Slave Timing (CPHA=0) . . . . .	121
Figure C-4	SPI Slave Timing (CPHA=1) . . . . .	122
Figure C-5	General External Bus Timing. . . . .	123
Figure D-1	80-pin QFP Mechanical Dimensions (case no. 841B). . . . .	128
Figure D-2	52-pin LQFP Mechanical Dimensions (case no. 848D-03) . . . . .	129

Figure D-3 48-pin LQFP Mechanical Dimensions (case no.932-03 ISSUE F) . . . . . 130  
Figure 19-1 Pin Assignments in 112-pin LQFP. . . . . 131  
Figure 19-2 112-pin LQFP mechanical dimensions (case no. 987)80-pin QFP Mechanical Di-  
mensions (case no. 841B)133

## List of Tables

Table 0-2	MC9S12C-Family Package Option Summary . . . . .	15
Table 0-1	List of MC9S12C and MC9S12GC Family members . . . . .	15
Table 0-3	MC9S12C-Family Part Number Coding . . . . .	16
Table 0-4	MC9S12GC-Family Part Number Coding . . . . .	19
Table 0-5	Document References . . . . .	21
Table 1-1	Device Register Map Overview . . . . .	28
	\$0000 - \$000F MEBI map 1 of 3 (HCS12 Multiplexed External Bus Interface)	34
	\$0010 - \$0014 MMC map 1 of 4 (HCS12 Module Mapping Control)	34
	\$0018 - \$0018 Miscellaneous Peripherals (Device User Guide)	35
	\$0019 - \$0019 VREG3V3 (Voltage Regulator)	35
	\$0015 - \$0016 INT map 1 of 2 (HCS12 Interrupt)	35
	\$0017 - \$0017 MMC map 2 of 4 (HCS12 Module Mapping Control)	35
	\$001A - \$001B Miscellaneous Peripherals (Device User Guide)	35
	\$001C - \$001D MMC map 3 of 4 (HCS12 Module Mapping Control, 36 Device User Guide)	36
	\$001E - \$001E MEBI map 2 of 3 (HCS12 Multiplexed External Bus Interface)	36
	\$001F - \$001F INT map 2 of 2 (HCS12 Interrupt)	36
	\$0020 - \$002F DBG (including BKP) map 1 of 1 (HCS12 Debug)	36
	\$0030 - \$0031 MMC map 4 of 4 (HCS12 Module Mapping Control)	37
	\$0032 - \$0033 MEBI map 3 of 3 (HCS12 Multiplexed External Bus Interface)	37
	\$0034 - \$003F CRG (Clock and Reset Generator)	37
	\$0040 - \$006F TIM (Timer 16 Bit 8 Channels)	38
	\$0070 - \$007F Reserved	40
	\$0080 - \$009F ATD (Analog to Digital Converter 10 Bit 8 Channel)	40
	\$00A0 - \$00C7 Reserved	41
	\$00D0 - \$00D7 Reserved	42
	\$00C8 - \$00CF SCI (Asynchronous Serial Interface)	42
	\$00D8 - \$00DF SPI (Serial Peripheral Interface)	42
	\$00E0 - \$00FF PWM (Pulse Width Modulator)	43
	\$0100 - \$010F Flash Control Register	44
	\$0110 - \$013F Reserved	45
	\$0140 - \$017F CAN (Motorola Scalable CAN - MSCAN)	45
Table 1-2	Detailed MSCAN Foreground Receive and Transmit Buffer Layout. . . . .	46

\$0180 - \$023F Reserved 47

\$0240 - \$027F PIM (Port Interface Module) 47

\$0280 - \$03FF Reserved space 50

Table 1-3	Assigned Part ID Numbers . . . . .	50
Table 1-4	Memory size registers . . . . .	50
Table 2-1	Signal Properties . . . . .	55
Table 2-2	MC9S12C-Family Power and Ground Connection Summary . . . . .	64
Table 4-1	Mode Selection . . . . .	66
Table 4-2	Clock Selection Based on PE7 . . . . .	66
Table 5-1	Interrupt Vector Locations . . . . .	68
Table 5-2	Reset Summary . . . . .	70
Table 6-1	Device Specific Flash PAGE Mapping. . . . .	71
Table 8-1	Recommended External Component Values. . . . .	73
Table A-1	Absolute Maximum Ratings . . . . .	85
Table A-2	ESD and Latch-up Test Conditions . . . . .	86
Table A-3	ESD and Latch-Up Protection Characteristics. . . . .	86
Table A-4	Operating Conditions . . . . .	87
Table A-5	Thermal Package Characteristics . . . . .	89
Table A-6	5V I/O Characteristics . . . . .	90
Table A-7	3.3V I/O Characteristics. . . . .	91
Table A-8	Supply Current Characteristics for MC9S12C32 . . . . .	93
Table A-9	Supply Current Characteristics for MC9S12C64,MC9S12C96,MC9S12C128 . . . . .	94
Table B-1	Voltage Regulator Electrical Parameters . . . . .	95
Table B-2	Voltage Regulator - Capacitive Loads . . . . .	97
Table B-3	ATD Operating Characteristics . . . . .	99
Table B-4	ATD Operating Characteristics . . . . .	100
Table B-5	ATD Electrical Characteristics . . . . .	101
Table B-6	ATD Conversion Performance . . . . .	102
Table B-7	ATD Conversion Performance . . . . .	102
Table B-8	NVM Timing Characteristics . . . . .	106
Table B-9	NVM Reliability Characteristics. . . . .	107
Table B-10	Startup Characteristics. . . . .	109
Table B-11	Oscillator Characteristics . . . . .	111
Table B-12	PLL Characteristics . . . . .	115
Table B-13	MSCAN Wake-up Pulse Characteristics. . . . .	117
Table C-1	Measurement Conditions. . . . .	119

Table C-2	SPI Master Mode Timing Characteristics. . . . .	120
Table C-3	SPI Slave Mode Timing Characteristics. . . . .	122
Table C-4	Expanded Bus Timing Characteristics (5V Range). . . . .	124
Table C-5	Expanded Bus Timing Characteristics (3.3V Range) . . . . .	125



## Preface

The Device User Guide provides information about the MC9S12C-Family as well the MC9S12GC-Family devices made up of standard HCS12 blocks and the HCS12 processor core. This document is part of the customer documentation. A complete set of device manuals also includes the HCS12 Core User Guide and all the individual Block User Guides of the implemented modules. In an effort to reduce redundancy all module specific information is located only in the respective Block User Guide. If applicable, special implementation details of the module are given in the block description sections of this document.

The C-Family and the GC-Family offer an extensive range of package, temperature and speed options. The members of the GC-Family do not feature a CAN module.

Table 0-1 shows a feature overview of the MC9S12C and MC9S12GC Family members.

Table 0-2 summarizes the package option and size configuration.

Table 0-3 lists the part number coding based on the package, speed and temperature and preliminary die options for the C-Family.

Table 0-4 lists the part number coding based on the package, speed and temperature and preliminary die options for the GC-Family.

**Table 0-1 List of MC9S12C and MC9S12GC Family members**

Flash	RAM	Device	CAN	SCI	SPI	A/D	PWM	Timer
128K	4K	MC9S12C128	1	1	1	8ch	6ch	8ch
		MC9S12GC128	—	1	1	8ch	6ch	8ch
96K	4K	MC9S12C96	1	1	1	8ch	6ch	8ch
64K	4K	MC9S12C64	1	1	1	8ch	6ch	8ch
		MC9S12GC64	—	1	1	8ch	6ch	8ch
32K	2K	MC9S12C32	1	1	1	8ch	6ch	8ch
		MC9S12GC32	—	1	1	8ch	6ch	8ch
16K	1K	MC9S12GC32	1	1	1	8ch	6ch	8ch

**Table 0-2 MC9S12C-Family Package Option Summary**

Package	Device	Part Number	Mask <sup>1</sup> set	Temp. <sup>2</sup> Options	Flash	RAM	I/O <sup>3,4</sup>
48LQFP	MC9S12C128	MC9S12C128	0L09S	M, V, C	128K	4K	31
52LQFP	MC9S12C128	MC9S12C128	0L09S	M, V, C			35
80QFP	MC9S12C128	MC9S12C128	0L09S	M, V, C			60
48LQFP	MC9S12C96	MC9S12C96	TBD	M, V, C	96K	4K	31
52LQFP	MC9S12C96	MC9S12C96	TBD	M, V, C			35
80QFP	MC9S12C96	MC9S12C96	TBD	M, V, C			60

Package	Device	Part Number	Mask <sup>1</sup> set	Temp. <sup>2</sup> Options	Flash	RAM	I/O <sup>3,4</sup>
48LQFP	MC9S12C64	MC9S12C64	TBD	M, V, C	64K	4K	31
52LQFP	MC9S12C64	MC9S12C64	TBD	M, V, C			35
80QFP	MC9S12C64	MC9S12C64	TBD	M, V, C			60
48LQFP	MC9S12C32	MC9S12C32	1L45J	M, V, C	32K	2K	31
52LQFP	MC9S12C32	MC9S12C32	1L45J	M, V, C			35
80QFP	MC9S12C32	MC9S12C32	1L45J	M, V, C			60
48LQFP	MC9S12GC128	MC9S12GC128	0L09S	M, V, C	128K	4K	31
52LQFP	MC9S12GC128	MC9S12GC128	0L09S	M, V, C			35
80QFP	MC9S12GC128	MC9S12GC128	0L09S	M, V, C			60
48LQFP	MC9S12GC128	MC9S12GC64	TBD	M, V, C	64K	4K	31
52LQFP	MC9S12GC128	MC9S12GC64	TBD	M, V, C			35
80QFP	MC9S12GC128	MC9S12GC64	TBD	M, V, C			60
48LQFP	MC9S12GC32	MC9S12GC32	1L45J	M, V, C	32K	2K	31
52LQFP	MC9S12GC32	MC9S12GC32	1L45J	M, V, C			35
80QFP	MC9S12GC32	MC9S12GC32	1L45J	M, V, C			60
48LQFP	MC9S12GC16	MC9S12GC16	1L45J	M, V, C	16K	2K	31
52LQFP	MC9S12GC16	MC9S12GC16	1L45J	M, V, C			35
80QFP	MC9S12GC16	MC9S12GC16	1L45J	M, V, C			60

NOTES:

1. Maskset dependent errata can be accessed at [http://e-www.motorola.com/wbapp/sps/site/prod\\_summary.jsp](http://e-www.motorola.com/wbapp/sps/site/prod_summary.jsp)
2. C: T<sub>A</sub> = 85°C, f = 25MHz. V: T<sub>A</sub> = 105°C, f = 25MHz. M: T<sub>A</sub> = 125°C, f = 25MHz
3. All C-Family derivatives feature 1 CAN, 1 SCI, 1 SPI, an 8-channel A/D, a 6-channel PWM and an 8 channel timer. The GC-Family members do not have the CAN module
4. I/O is the sum of ports capable to act as digital input or output.

**MC9S12 C32 (P)C FU 25**

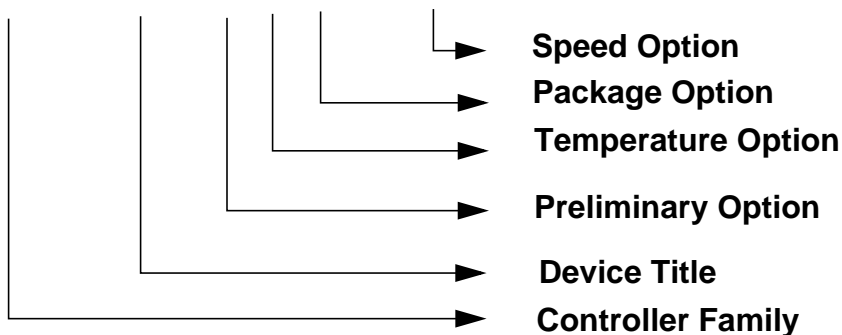

**Temperature Options**

C = -40°C to 85°C  
 V = -40°C to 105°C  
 M = -40°C to 125°C

**Package Options**

FU = 80QFP  
 PB = 52LQFP  
 FA = 48LQFP

**Speed Options**  
 25 = 25MHz bus  
 16 = 16MHz bus

**Figure 0-1 Order Part number Coding**

**Table 0-3 MC9S12C-Family Part Number Coding**

Part Number	Mask set	Temp.	Package	Speed	Description
MC9S12C128CFA16	TBD	-40°C, 85°C	48LQFP	16MHz	C128 die

Part Number	Mask set	Temp.	Package	Speed	Description
MC9S12C128CPB16	TBD	-40°C, 85°C	52LQFP	16MHz	C128 die
MC9S12C128CFU16	TBD	-40°C, 85°C	80QFP	16MHz	C128 die
MC9S12C128VFA16	TBD	-40°C, 105°C	48LQFP	16MHz	C128 die
MC9S12C128VPB16	TBD	-40°C, 105°C	52LQFP	16MHz	C128 die
MC9S12C128VFU16	TBD	-40°C, 105°C	80QFP	16MHz	C128 die
MC9S12C128MFA16	TBD	-40°C, 125°C	48LQFP	16MHz	C128 die
MC9S12C128MPB16	TBD	-40°C, 125°C	52LQFP	16MHz	C128 die
MC9S12C128MFU16	TBD	-40°C, 125°C	80QFP	16MHz	C128 die
MC9S12C128CFA25	TBD	-40°C, 85°C	48LQFP	25MHz	C128 die
MC9S12C128CPB25	TBD	-40°C, 85°C	52LQFP	25MHz	C128 die
MC9S12C128CFU25	TBD	-40°C, 85°C	80QFP	25MHz	C128 die
MC9S12C128VFA25	TBD	-40°C, 105°C	48LQFP	25MHz	C128 die
MC9S12C128VPB25	TBD	-40°C, 105°C	52LQFP	25MHz	C128 die
MC9S12C128VFU25	TBD	-40°C, 105°C	80QFP	25MHz	C128 die
MC9S12C128MFA25	TBD	-40°C, 125°C	48LQFP	25MHz	C128 die
MC9S12C128MPB25	TBD	-40°C, 125°C	52LQFP	25MHz	C128 die
MC9S12C128MFU25	TBD	-40°C, 125°C	80QFP	25MHz	C128 die
MC9S12C96PCFA16	0L09S	-40°C, 85°C	48LQFP	16MHz	Preliminary C96 using C128 die
MC9S12C96PCPB16	0L09S	-40°C, 85°C	52LQFP	16MHz	Preliminary C96 using C128 die
MC9S12C96PCFU16	0L09S	-40°C, 85°C	80QFP	16MHz	Preliminary C96 using C128 die
MC9S12C96CFA16	TBD	-40°C, 85°C	48LQFP	16MHz	Final C96 using C96 die
MC9S12C96CPB16	TBD	-40°C, 85°C	52LQFP	16MHz	Final C96 using C96 die
MC9S12C96CFU16	TBD	-40°C, 85°C	80QFP	16MHz	Final C96 using C96 die
MC9S12C96PVFA16	0L09S	-40°C, 105°C	48LQFP	16MHz	Preliminary C96 using C128 die
MC9S12C96PVPB16	0L09S	-40°C, 105°C	52LQFP	16MHz	Preliminary C96 using C128 die
MC9S12C96PVFU16	0L09S	-40°C, 105°C	80QFP	16MHz	Preliminary C96 using C128 die
MC9S12C96VFA16	TBD	-40°C, 105°C	48LQFP	16MHz	Final C96 using C96 die
MC9S12C96VPB16	TBD	-40°C, 105°C	52LQFP	16MHz	Final C96 using C96 die
MC9S12C96VFU16	TBD	-40°C, 105°C	80QFP	16MHz	Final C96 using C96 die
MC9S12C96PMFA16	0L09S	-40°C, 125°C	48LQFP	16MHz	Preliminary C96 using C128 die
MC9S12C96PMPB16	0L09S	-40°C, 125°C	52LQFP	16MHz	Preliminary C96 using C128 die
MC9S12C96PMFU16	0L09S	-40°C, 125°C	80QFP	16MHz	Preliminary C96 using C128 die
MC9S12C96MFA16	TBD	-40°C, 125°C	48LQFP	16MHz	Final C96 using C96 die
MC9S12C96MPB16	TBD	-40°C, 125°C	52LQFP	16MHz	Final C96 using C96 die
MC9S12C96MFU16	TBD	-40°C, 125°C	80QFP	16MHz	Final C96 using C96 die
MC9S12C96PCFA25	0L09S	-40°C, 85°C	48LQFP	25MHz	Preliminary C96 using C128 die
MC9S12C96PCPB25	0L09S	-40°C, 85°C	52LQFP	25MHz	Preliminary C96 using C128 die
MC9S12C96PCFU25	0L09S	-40°C, 85°C	80QFP	25MHz	Preliminary C96 using C128 die
MC9S12C96CFA25	TBD	-40°C, 85°C	48LQFP	25MHz	Final C96 using C96 die
MC9S12C96CPB25	TBD	-40°C, 85°C	52LQFP	25MHz	Final C96 using C96 die
MC9S12C96CFU25	TBD	-40°C, 85°C	80QFP	25MHz	Final C96 using C96 die
MC9S12C96PVFA25	0L09S	-40°C, 105°C	48LQFP	25MHz	Preliminary C96 using C128 die
MC9S12C96PVPB25	0L09S	-40°C, 105°C	52LQFP	25MHz	Preliminary C96 using C128 die
MC9S12C96PVFU25	0L09S	-40°C, 105°C	80QFP	25MHz	Preliminary C96 using C128 die

Part Number	Mask set	Temp.	Package	Speed	Description
MC9S12C96VFA25	TBD	-40°C, 105°C	48LQFP	25MHz	Final C96 using C96 die
MC9S12C96VPB25	TBD	-40°C, 105°C	52LQFP	25MHz	Final C96 using C96 die
MC9S12C96VFU25	TBD	-40°C, 105°C	80QFP	25MHz	Final C96 using C96 die
MC9S12C96PMFA25	0L09S	-40°C, 125°C	48LQFP	25MHz	Preliminary C96 using C128 die
MC9S12C96PMPB25	0L09S	-40°C, 125°C	52LQFP	25MHz	Preliminary C96 using C128 die
MC9S12C96PMFU25	0L09S	-40°C, 125°C	80QFP	25MHz	Preliminary C96 using C128 die
MC9S12C96MFA25	TBD	-40°C, 125°C	48LQFP	25MHz	Final C96 using C96 die
MC9S12C96MPB25	TBD	-40°C, 125°C	52LQFP	25MHz	Final C96 using C96 die
MC9S12C96MFU25	TBD	-40°C, 125°C	80QFP	25MHz	Final C96 using C96 die
MC9S12C64PCFA16	0L09S	-40°C, 85°C	48LQFP	16MHz	Preliminary C64 using C128 die
MC9S12C64PCPB16	0L09S	-40°C, 85°C	52LQFP	16MHz	Preliminary C64 using C128 die
MC9S12C64PCFU16	0L09S	-40°C, 85°C	80QFP	16MHz	Preliminary C64 using C128 die
MC9S12C64CFA16	TBD	-40°C, 85°C	48LQFP	16MHz	Final C64 using C64 die
MC9S12C64CPB16	TBD	-40°C, 85°C	52LQFP	16MHz	Final C64 using C64 die
MC9S12C64CFU16	TBD	-40°C, 85°C	80QFP	16MHz	Final C64 using C64 die
MC9S12C64PVFA16	0L09S	-40°C, 105°C	48LQFP	16MHz	Preliminary C64 using C128 die
MC9S12C64PVPB16	0L09S	-40°C, 105°C	52LQFP	16MHz	Preliminary C64 using C128 die
MC9S12C64PVFU16	0L09S	-40°C, 105°C	80QFP	16MHz	Preliminary C64 using C128 die
MC9S12C64VFA16	TBD	-40°C, 105°C	48LQFP	16MHz	Final C64 using C64 die
MC9S12C64VPB16	TBD	-40°C, 105°C	52LQFP	16MHz	Final C64 using C64 die
MC9S12C64VFU16	TBD	-40°C, 105°C	80QFP	16MHz	Final C64 using C64 die
MC9S12C64PMFA16	0L09S	-40°C, 125°C	48LQFP	16MHz	Preliminary C64 using C128 die
MC9S12C64PMPB16	0L09S	-40°C, 125°C	52LQFP	16MHz	Preliminary C64 using C128 die
MC9S12C64PMFU16	0L09S	-40°C, 125°C	80QFP	16MHz	Preliminary C64 using C128 die
MC9S12C64MFA16	TBD	-40°C, 125°C	48LQFP	16MHz	Final C64 using C64 die
MC9S12C64MPB16	TBD	-40°C, 125°C	52LQFP	16MHz	Final C64 using C64 die
MC9S12C64MFU16	TBD	-40°C, 125°C	80QFP	16MHz	Final C64 using C64 die
MC9S12C64PCFA25	0L09S	-40°C, 85°C	48LQFP	25MHz	Preliminary C64 using C128 die
MC9S12C64PCPB25	0L09S	-40°C, 85°C	52LQFP	25MHz	Preliminary C64 using C128 die
MC9S12C64PCFU25	0L09S	-40°C, 85°C	80QFP	25MHz	Preliminary C64 using C128 die
MC9S12C64CFA25	TBD	-40°C, 85°C	48LQFP	25MHz	Final C64 using C64 die
MC9S12C64CPB25	TBD	-40°C, 85°C	52LQFP	25MHz	Final C64 using C64 die
MC9S12C64CFU25	TBD	-40°C, 85°C	80QFP	25MHz	Final C64 using C64 die
MC9S12C64PVFA25	0L09S	-40°C, 105°C	48LQFP	25MHz	Preliminary C64 using C128 die
MC9S12C64PVPB25	0L09S	-40°C, 105°C	52LQFP	25MHz	Preliminary C64 using C128 die
MC9S12C64PVFU25	0L09S	-40°C, 105°C	80QFP	25MHz	Preliminary C64 using C128 die
MC9S12C64VFA25	TBD	-40°C, 105°C	48LQFP	25MHz	Final C64 using C64 die
MC9S12C64VPB25	TBD	-40°C, 105°C	52LQFP	25MHz	Final C64 using C64 die
MC9S12C64VFU25	TBD	-40°C, 105°C	80QFP	25MHz	Final C64 using C64 die
MC9S12C64PMFA25	0L09S	-40°C, 125°C	48LQFP	25MHz	Preliminary C64 using C128 die
MC9S12C64PMPB25	0L09S	-40°C, 125°C	52LQFP	25MHz	Preliminary C64 using C128 die
MC9S12C64PMFU25	0L09S	-40°C, 125°C	80QFP	25MHz	Preliminary C64 using C128 die
MC9S12C64MFA25	TBD	-40°C, 125°C	48LQFP	25MHz	Final C64 using C64 die
MC9S12C64MPB25	TBD	-40°C, 125°C	52LQFP	25MHz	Final C64 using C64 die

Part Number	Mask set	Temp.	Package	Speed	Description
MC9S12C64MFU25	TBD	-40°C, 125°C	80QFP	25MHz	Final C64 using C64 die
MC9S12C32CFA16	1L45J	-40°C, 85°C	48LQFP	16MHz	C32 die
MC9S12C32CPB16	1L45J	-40°C, 85°C	52LQFP	16MHz	C32 die
MC9S12C32CFU16	1L45J	-40°C, 85°C	80QFP	16MHz	C32 die
MC9S12C32VFA16	1L45J	-40°C, 105°C	48LQFP	16MHz	C32 die
MC9S12C32VPB16	1L45J	-40°C, 105°C	52LQFP	16MHz	C32 die
MC9S12C32VFU16	1L45J	-40°C, 105°C	80QFP	16MHz	C32 die
MC9S12C32MFA16	1L45J	-40°C, 125°C	48LQFP	16MHz	C32 die
MC9S12C32MPB16	1L45J	-40°C, 125°C	52LQFP	16MHz	C32 die
MC9S12C32MFU16	1L45J	-40°C, 125°C	80QFP	16MHz	C32 die
MC9S12C32CFA25	1L45J	-40°C, 85°C	48LQFP	25MHz	C32 die
MC9S12C32CPB25	1L45J	-40°C, 85°C	52LQFP	25MHz	C32 die
MC9S12C32CFU25	1L45J	-40°C, 85°C	80QFP	25MHz	C32 die
MC9S12C32VFA25	1L45J	-40°C, 105°C	48LQFP	25MHz	C32 die
MC9S12C32VPB25	1L45J	-40°C, 105°C	52LQFP	25MHz	C32 die
MC9S12C32VFU25	1L45J	-40°C, 105°C	80QFP	25MHz	C32 die
MC9S12C32MFA25	1L45J	-40°C, 125°C	48LQFP	25MHz	C32 die
MC9S12C32MPB25	1L45J	-40°C, 125°C	52LQFP	25MHz	C32 die
MC9S12C32MFU25	1L45J	-40°C, 125°C	80QFP	25MHz	C32 die

Table 0-4 MC9S12GC-Family Part Number Coding

Part Number	Mask set	Temp.	Package	Speed	Description
MC9S12GC128PCFA25	0L09S	-40°C, 85°C	48LQFP	25MHz	Preliminary GC128 using C128 die
MC9S12GC128PCPB25	0L09S	-40°C, 85°C	52LQFP	25MHz	Preliminary GC128 using C128 die
MC9S12GC128PCFU25	0L09S	-40°C, 85°C	80QFP	25MHz	Preliminary GC128 using C128 die
MC9S12GC128CFA25	TBD	-40°C, 85°C	48LQFP	25MHz	Final GC128 using GC128 die
MC9S12GC128CPB25	TBD	-40°C, 85°C	52LQFP	25MHz	Final GC128 using GC128 die
MC9S12GC128CFU25	TBD	-40°C, 85°C	80QFP	25MHz	Final GC128 using GC128 die
MC9S12GC128PVFA25	0L09S	-40°C, 105°C	48LQFP	25MHz	Preliminary GC128 using C128 die
MC9S12GC128PVPB25	0L09S	-40°C, 105°C	52LQFP	25MHz	Preliminary GC128 using C128 die
MC9S12GC128PVFU25	0L09S	-40°C, 105°C	80QFP	25MHz	Preliminary GC128 using C128 die
MC9S12GC128VFA25	TBD	-40°C, 105°C	48LQFP	25MHz	Final GC128 using GC128 die
MC9S12GC128VPB25	TBD	-40°C, 105°C	52LQFP	25MHz	Final GC128 using GC128 die
MC9S12GC128VFU25	TBD	-40°C, 105°C	80QFP	25MHz	Final GC128 using GC128 die
MC9S12GC128PMFA25	0L09S	-40°C, 125°C	48LQFP	25MHz	Preliminary GC128 using C128 die
MC9S12GC128PMPB25	0L09S	-40°C, 125°C	52LQFP	25MHz	Preliminary GC128 using C128 die
MC9S12GC128PMFU25	0L09S	-40°C, 125°C	80QFP	25MHz	Preliminary GC128 using C128 die
MC9S12GC128MFA25	TBD	-40°C, 125°C	48LQFP	25MHz	Final GC128 using GC128 die
MC9S12GC128MPB25	TBD	-40°C, 125°C	52LQFP	25MHz	Final GC128 using GC128 die
MC9S12GC128MFU25	TBD	-40°C, 125°C	80QFP	25MHz	Final GC128 using GC128 die
MC9S12GC64PCFA25	0L09S	-40°C, 85°C	48LQFP	25MHz	Preliminary GC64 using C128 die
MC9S12GC64PCPB25	0L09S	-40°C, 85°C	52LQFP	25MHz	Preliminary GC64 using C128 die
MC9S12GC64PCFU25	0L09S	-40°C, 85°C	80QFP	25MHz	Preliminary GC64 using C128 die

Part Number	Mask set	Temp.	Package	Speed	Description
MC9S12GC64CFA25	TBD	-40°C, 85°C	48LQFP	25MHz	Final GC64 using GC64 die
MC9S12GC64CPB25	TBD	-40°C, 85°C	52LQFP	25MHz	Final GC64 using GC64 die
MC9S12GC64CFU25	TBD	-40°C, 85°C	80QFP	25MHz	Final GC64 using GC64 die
MC9S12GC64PVFA25	0L09S	-40°C, 105°C	48LQFP	25MHz	Preliminary GC64 using C128 die
MC9S12GC64PVPB25	0L09S	-40°C, 105°C	52LQFP	25MHz	Preliminary GC64 using C128 die
MC9S12GC64PVFU25	0L09S	-40°C, 105°C	80QFP	25MHz	Preliminary GC64 using C128 die
MC9S12GC64VFA25	TBD	-40°C, 105°C	48LQFP	25MHz	Final GC64 using GC64 die
MC9S12GC64VPB25	TBD	-40°C, 105°C	52LQFP	25MHz	Final GC64 using GC64 die
MC9S12GC64VFU25	TBD	-40°C, 105°C	80QFP	25MHz	Final GC64 using GC64 die
MC9S12GC64PMFA25	0L09S	-40°C, 125°C	48LQFP	25MHz	Preliminary GC64 using C128 die
MC9S12GC64PMPB25	0L09S	-40°C, 125°C	52LQFP	25MHz	Preliminary GC64 using C128 die
MC9S12GC64PMFU25	0L09S	-40°C, 125°C	80QFP	25MHz	Preliminary GC64 using C128 die
MC9S12GC64MFA25	TBD	-40°C, 125°C	48LQFP	25MHz	Final GC64 using GC64 die
MC9S12GC64MPB25	TBD	-40°C, 125°C	52LQFP	25MHz	Final GC64 using GC64 die
MC9S12GC64MFU25	TBD	-40°C, 125°C	80QFP	25MHz	Final GC64 using GC64 die
MC9S12GC32PCFA25	1L45J	-40°C, 85°C	48LQFP	25MHz	Preliminary GC32 using C32 die
MC9S12GC32PCPB25	1L45J	-40°C, 85°C	52LQFP	25MHz	Preliminary GC32 using C32 die
MC9S12GC32PCFU25	1L45J	-40°C, 85°C	80QFP	25MHz	Preliminary GC32 using C32 die
MC9S12GC32CFA25	TBD	-40°C, 85°C	48LQFP	25MHz	Final GC32 using GC32 die
MC9S12GC32CPB25	TBD	-40°C, 85°C	52LQFP	25MHz	Final GC32 using GC32 die
MC9S12GC32CFU25	TBD	-40°C, 85°C	80QFP	25MHz	Final GC32 using GC32 die
MC9S12GC32PVFA25	1L45J	-40°C, 105°C	48LQFP	25MHz	Preliminary GC32 using C32 die
MC9S12GC32PVPB25	1L45J	-40°C, 105°C	52LQFP	25MHz	Preliminary GC32 using C32 die
MC9S12GC32PVFU25	1L45J	-40°C, 105°C	80QFP	25MHz	Preliminary GC32 using C32 die
MC9S12GC32VFA25	TBD	-40°C, 105°C	48LQFP	25MHz	Final GC32 using GC32 die
MC9S12GC32VPB25	TBD	-40°C, 105°C	52LQFP	25MHz	Final GC32 using GC32 die
MC9S12GC32VFU25	TBD	-40°C, 105°C	80QFP	25MHz	Final GC32 using GC32 die
MC9S12GC32PMFA25	1L45J	-40°C, 125°C	48LQFP	25MHz	Preliminary GC32 using C32 die
MC9S12GC32PMPB25	1L45J	-40°C, 125°C	52LQFP	25MHz	Preliminary GC32 using C32 die
MC9S12GC32PMFU25	1L45J	-40°C, 125°C	80QFP	25MHz	Preliminary GC32 using C32 die
MC9S12GC32MFA25	TBD	-40°C, 125°C	48LQFP	25MHz	Final GC32 using GC32 die
MC9S12GC32MPB25	TBD	-40°C, 125°C	52LQFP	25MHz	Final GC32 using GC32 die
MC9S12GC32MFU25	TBD	-40°C, 125°C	80QFP	25MHz	Final GC32 using GC32 die
MC9S12GC16PCFA25	1L45J	-40°C, 85°C	48LQFP	25MHz	Preliminary GC16 using C32 die
MC9S12GC16PCPB25	1L45J	-40°C, 85°C	52LQFP	25MHz	Preliminary GC16 using C32 die
MC9S12GC16PCFU25	1L45J	-40°C, 85°C	80QFP	25MHz	Preliminary GC16 using C32 die
MC9S12GC16CFA25	TBD	-40°C, 85°C	48LQFP	25MHz	Final GC16 using GC16 die
MC9S12GC16CPB25	TBD	-40°C, 85°C	52LQFP	25MHz	Final GC16 using GC16 die
MC9S12GC16CFU25	TBD	-40°C, 85°C	80QFP	25MHz	Final GC16 using GC16 die
MC9S12GC16PVFA25	1L45J	-40°C, 105°C	48LQFP	25MHz	Preliminary GC16 using C32 die
MC9S12GC16PVPB25	1L45J	-40°C, 105°C	52LQFP	25MHz	Preliminary GC16 using C32 die
MC9S12GC16PVFU25	1L45J	-40°C, 105°C	80QFP	25MHz	Preliminary GC16 using C32 die
MC9S12GC16VFA25	TBD	-40°C, 105°C	48LQFP	25MHz	Final GC16 using GC16 die
MC9S12GC16VPB25	TBD	-40°C, 105°C	52LQFP	25MHz	Final GC16 using GC16 die

Part Number	Mask set	Temp.	Package	Speed	Description
MC9S12GC16VFU25	TBD	-40°C, 105°C	80QFP	25MHz	Final GC16 using GC16 die
MC9S12GC16PMFA25	1L45J	-40°C, 125°C	48LQFP	25MHz	Preliminary GC16 using C32 die
MC9S12GC16PMPB25	1L45J	-40°C, 125°C	52LQFP	25MHz	Preliminary GC16 using C32 die
MC9S12GC16PMFU25	1L45J	-40°C, 125°C	80QFP	25MHz	Preliminary GC16 using C32 die
MC9S12GC16MFA25	TBD	-40°C, 125°C	48LQFP	25MHz	Final GC16 using GC16 die
MC9S12GC16MPB25	TBD	-40°C, 125°C	52LQFP	25MHz	Final GC16 using GC16 die
MC9S12GC16MFU25	TBD	-40°C, 125°C	80QFP	25MHz	Final GC16 using GC16 die

**Table 0-5 Document References**

User Guide <sup>1</sup>	Version	Document Order Number
CPU12 Reference Manual	V02	S12CPUV2/D
HCS12 Debug (DBG) Block Guide	V01	S12DBGV1/D
HCS12 Background Debug (BDM) Block Guide	V04	S12BDMV4/D
HCS12 Module Mapping Control (MMC) Block Guide	V04	S12MMCV4/D
HCS12 Multiplexed External Bus Interface (MEBI) Block Guide	V03	S12MEBIV3/D
HCS12 Interrupt (INT) Block Guide	V01	S12INTV1/D
Analog To Digital Converter: 10 Bit 8 Channel (ATD_10B8C) Block Guide	V02	S12ATD10B8CV2/D
Clock and Reset Generator (CRG) Block Guide	V04	S12CRGV4/D
Serial Communications Interface (SCI) Block Guide	V02	S12SCIV2/D
Serial Peripheral Interface (SPI) Block Guide	V03	S12SPIV3/D
Motorola Scalable CAN (MSCAN) Block Guide <sup>2</sup>	V02	S12MSCANV2/D
Pulse Width Modulator: 8 bit, 6 channel (PWM_8B6C) Block Guide	V01	S12PWM8B6V1/D
Timer: 16 bit, 8 channel (TIM_16B8C) Block Guide	V01	S12TIM16B8CV1/D
Voltage Regulator (VREG) Block Guide	V02	S12VREG3V3V2/D
Oscillator (OSC) Block Guide	V02	S12OSCV2/D
Port Integration Module (PIM_9C32) Block Guide	V01	S12C32PIMV1/D
32Kbyte Flash EEPROM (FTS32K) Block Guide	V01	S12FTS32KV1/D
64Kbyte Flash EEPROM (FTS64K) Block Guide	V01	S12FTS64KV1/D
128Kbyte Flash EEPROM (FTS128K1) Block Guide	V01	S12FTS128K1V1/D

**NOTES:**

1. For the GC16 refer to the 16K flash, for the C32 and GC32 refer to the 32K flash, for the C64 and GC64 the 64K flash, for the C96 the 96K flash and C128 the 128K flash document.
2. Not available on the GC-Family members

## Terminology

Acronyms and Abbreviations	
New or invented terms, symbols, and notations	



# Section 1 Introduction

## 1.1 Overview

The MC9S12C-Family and the MC9S12GC-Family is a 48/52/80 pin Flash-based Industrial/Automotive network control MCU family. Members of the MC9S12C-Family and the MC9S12GC-Family deliver the power and flexibility of our 16 Bit core (CPU12) family to a whole new range of cost and space sensitive, general purpose Industrial and Automotive network applications. All MC9S12C-Family and MC9S12GC-Family members are comprised of standard on-chip peripherals including a 16-bit central processing unit (CPU12), up to 128K bytes of Flash EEPROM, up to 4K bytes of RAM, an asynchronous serial communications interface (SCI), a serial peripheral interface (SPI), an 8-channel 16-bit timer module (TIM), a 6-channel 8-bit Pulse Width Modulator (PWM), an 8-channel, 10-bit analog-to-digital converter (ADC). The MC9S12C-Family members also feature a CAN 2.0 A, B software compatible module (MSCAN12). The MC9S12C-Family as well as the MC9S12GC-Family has full 16-bit data paths throughout. The inclusion of a PLL circuit allows power consumption and performance to be adjusted to suit operational requirements. In addition to the I/O ports available in each module, up to 10 dedicated I/O port bits are available with Wake-Up capability from STOP or WAIT mode. The MC9S12C-Family and the MC9S12GC-Family devices are available in 48, 52 and 80 pin QFP packages, with the 80 Pin version pin compatible to the HCS12 A, B and D- Family derivatives.

## 1.2 Features

- 16-bit HCS12 CORE
  - HCS12 CPU
    - i. Upward compatible with M68HC11 instruction set
    - ii. Interrupt stacking and programmer's model identical to M68HC11
    - iii. Instruction queue
    - iv. Enhanced indexed addressing
  - MMC (memory map and interface)
  - INT (interrupt control)
  - BDM (background debug mode)
  - DBG12 (enhanced debug12 module, including breakpoints and change-of-flow trace buffer)
  - MEBI: Multiplexed Expansion Bus Interface (available only in 80 pin package version)
- Wake-up interrupt inputs
  - Up to 12-port bits available for wake up interrupt function with digital filtering
- Memory options
  - 16K, 32K, 64K, 96K or 128KByte Flash EEPROM (erasable in 512-byte sectors)
  - 1K, 2K or 4K Byte RAM

- Analog-to-Digital Converters
  - One 8-channel module with 10-bit resolution.
  - External conversion trigger capability
- Available on MC9S12C-Family:  
One 1M bit per second, CAN 2.0 A, B software compatible module
  - Five receive and three transmit buffers
  - Flexible identifier filter programmable as 2 x 32 bit, 4 x 16 bit or 8 x 8 bit
  - Four separate interrupt channels for Rx, Tx, error and wake-up
  - Low-pass filter wake-up function
  - Loop-back for self test operation
- Timer Module (TIM)
  - 8-Channel Timer
  - Each Channel Configurable as either Input Capture or Output Compare
  - Simple PWM Mode
  - Modulo Reset of Timer Counter
  - 16-Bit Pulse Accumulator
  - External Event Counting
  - Gated Time Accumulation
- 6 PWM channels
  - Programmable period and duty cycle
  - 8-bit 6-channel or 16-bit 3-channel
  - Separate control for each pulse width and duty cycle
  - Center-aligned or left-aligned outputs
  - Programmable clock select logic with a wide range of frequencies
  - Fast emergency shutdown input
- Serial interfaces
  - One asynchronous serial communications interface (SCI)
  - One synchronous serial peripheral interface (SPI)
- CRG (Clock Reset Generator Module)
  - Windowed COP watchdog,
  - Real time interrupt,
  - Clock monitor,
  - Pierce or low current Colpitts oscillator

- Phase-locked loop clock frequency multiplier
- Limp home mode in absence of external clock
- Low power 0.5 to 16 MHz crystal oscillator reference clock
- Operating frequency
  - 32MHz equivalent to 16MHz Bus Speed for single chip
  - 32MHz equivalent to 16MHz Bus Speed in expanded bus modes
  - Option of 9S12C-Family: 50MHz equivalent to 25MHz Bus Speed
  - All 9S12GC-Family Members allow a 50MHz operating frequency.
- Internal 2.5V Regulator
  - Supports an input voltage range from 2.97V to 5.5V
  - Low power mode capability
  - Includes low voltage reset (LVR) circuitry
  - Includes low voltage interrupt (LVI) circuitry
- 48-Pin LQFP, 52-Pin LQFP or 80-Pin QFP package
  - Up to 58 I/O lines with 5V input and drive capability (80 pin package)
  - Up to 2 dedicated 5V input only lines (IRQ, XIRQ)
  - 5V 8 A/D converter inputs and 5V I/O
- Development support
  - Single-wire background debug™ mode (BDM)
  - On-chip hardware breakpoints
  - Enhanced DBG12 debug features

## 1.3 Modes of Operation

User modes (**Expanded modes are only available in the 80 pin package version**).

- Normal and Emulation Operating Modes
  - Normal Single-Chip Mode
  - Normal Expanded Wide Mode
  - Normal Expanded Narrow Mode
  - Emulation Expanded Wide Mode
  - Emulation Expanded Narrow Mode
- Special Operating Modes
  - Special Single-Chip Mode with active Background Debug Mode

- Special Test Mode (**Motorola use only**)
- Special Peripheral Mode (**Motorola use only**)
- Low power modes
  - Stop Mode
  - Pseudo Stop Mode
  - Wait Mode

# 1.4 Block Diagram

Figure 1-1 MC9S12C-Family Block Diagram

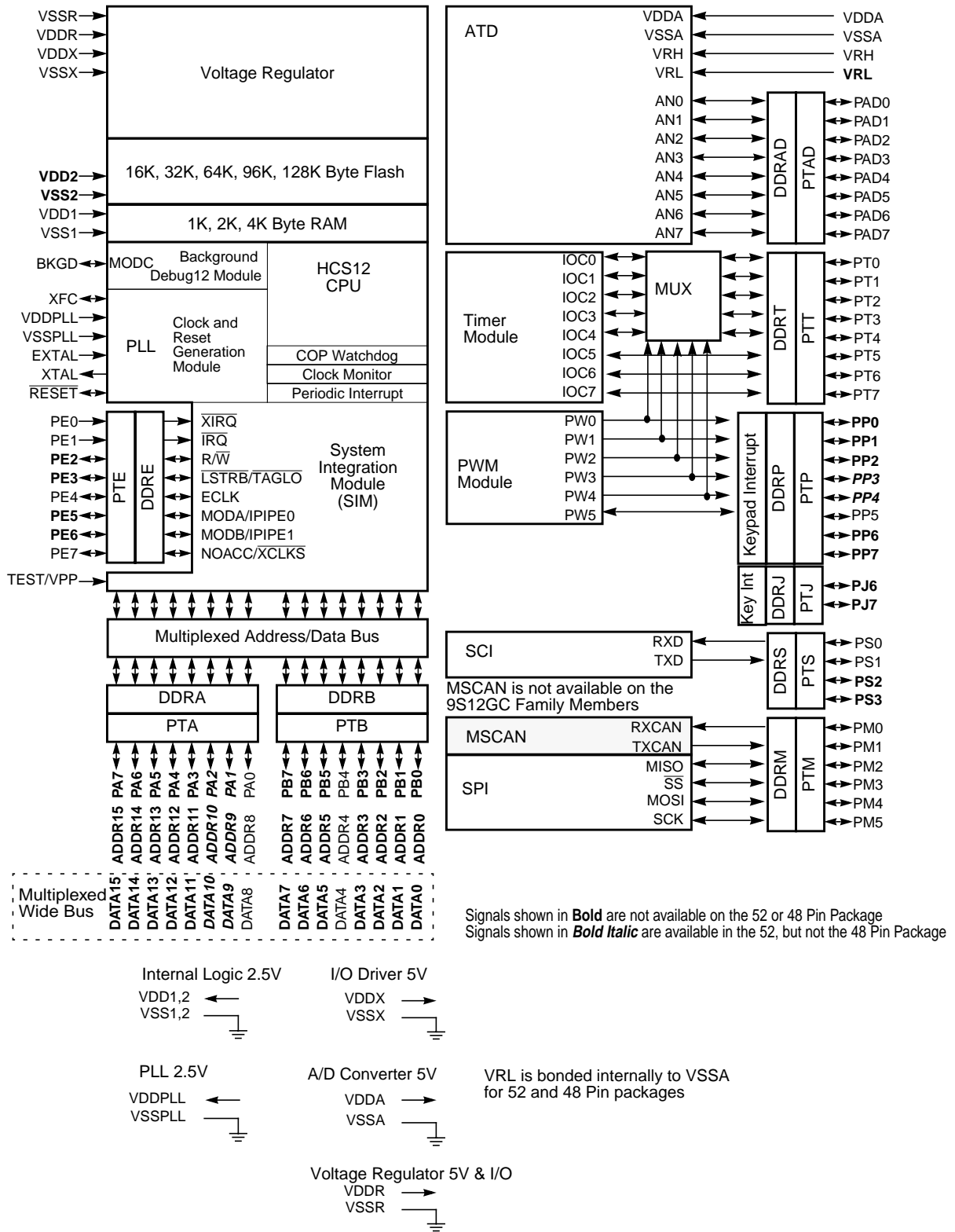

## 1.5 Device Memory Map

**Table 1-1** shows the device register map of the MC9S12C-Family after reset. The following figures (**Figure 1-2**, **Figure 1-2**, **Figure 1-3** and **Figure 1-4**) illustrate the full device memory map with flash and RAM.

**Table 1-1 Device Register Map Overview**

Address	Module	Size
\$000 - \$017	CORE (Ports A, B, E, Modes, Inits, Test)	24
\$018	Reserved	1
\$019	Voltage Regulator (VREG)	1
\$01A - \$01B	Device ID register	2
\$01C - \$01F	CORE (MEMSIZ, IRQ, HPRIO)	4
\$020 - \$02F	CORE (DBG)	16
\$030 - \$033	CORE (PPAGE <sup>1</sup> )	4
\$034 - \$03F	Clock and Reset Generator (CRG)	12
\$040 - \$06F	Standard Timer Module 16-bit 8-channels (TIM)	48
\$070 - \$07F	Reserved	16
\$080 - \$09F	Analog to Digital Convert (ATD)	32
\$0A0 - \$0C7	Reserved	40
\$0C8 - \$0CF	Serial Communications Interface (SCI)	8
\$0D0 - \$0D7	Reserved	8
\$0D8 - \$0DF	Serial Peripheral Interface (SPI)	8
\$0E0 - \$0FF	Pulse Width Modulator 8-bit 6 channels (PWM)	32
\$100 - \$10F	Flash Control Register	16
\$110 - \$13F	Reserved	48
\$140 - \$17F	Motorola Scalable CAN (MSCAN) <sup>2</sup>	64
\$180 - \$23F	Reserved	192
\$240 - \$27F	Port Integration Module (PIM)	64
\$280 - \$3FF	Reserved	384

NOTES:

1. External memory paging is not supported on this device (**6.1.1 PPAGE**).
2. Not available on MC9S12GC-Family Devices

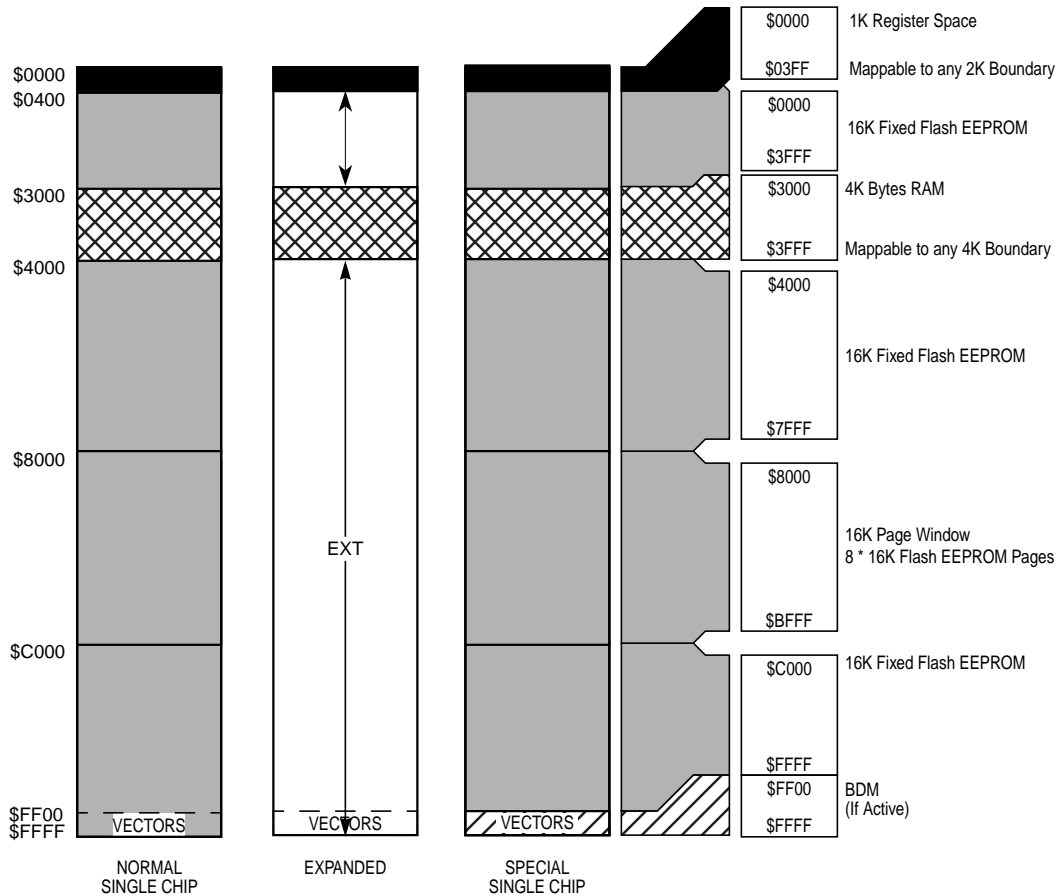

The figure shows a useful map, which is not the map out of reset. After reset the map is:

\$0000 - \$03FF: Register Space  
 \$0000 - \$0FFF: 4K RAM (only 3K visible \$0400 - \$0FFF)

Flash Erase Sector Size is 1024 Bytes

**Figure 1-2 MC9S12C128 and MC9S12GC128 User configurable Memory Map**

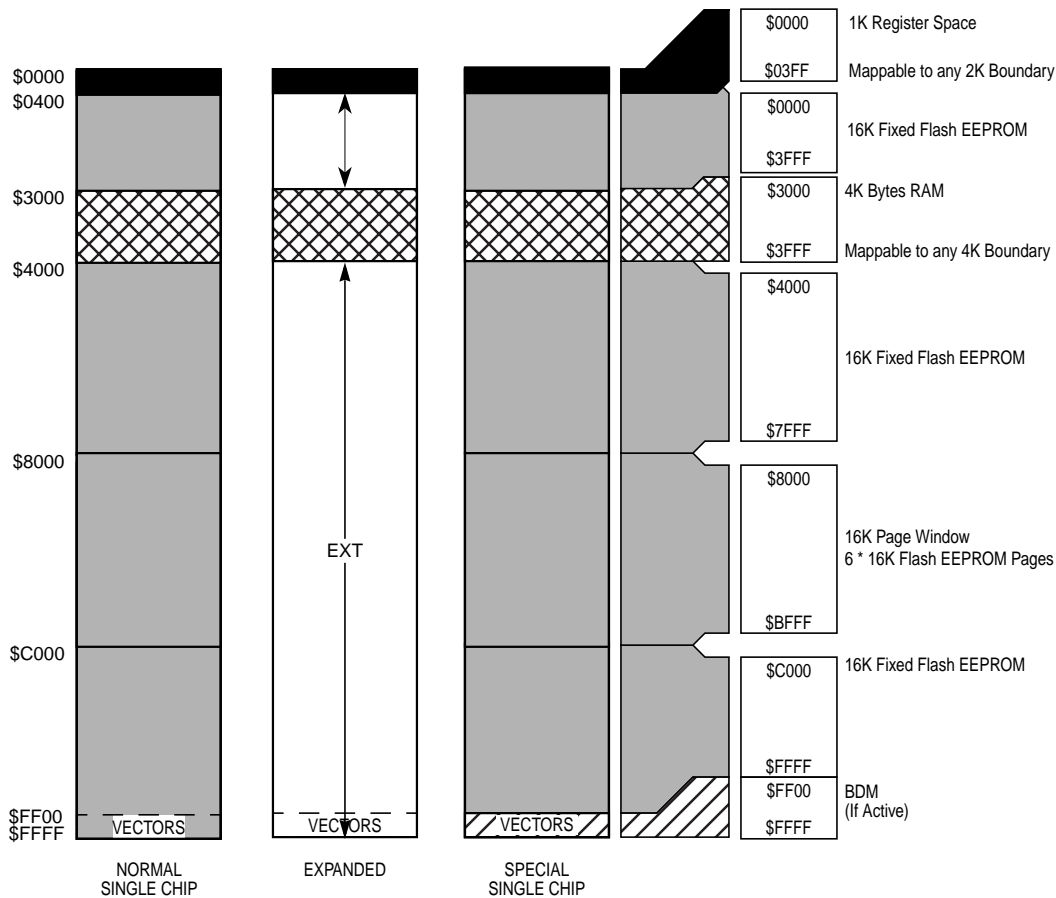

The figure shows a useful map, which is not the map out of reset. After reset the map is:

- \$0000 - \$03FF: Register Space
- \$0000 - \$0FFF: 4K RAM (only 3K visible \$0400 - \$0FFF)

Flash Erase Sector Size is 1024 Bytes

**Figure 1-3 MC9S12C96 User Configurable Memory Map**

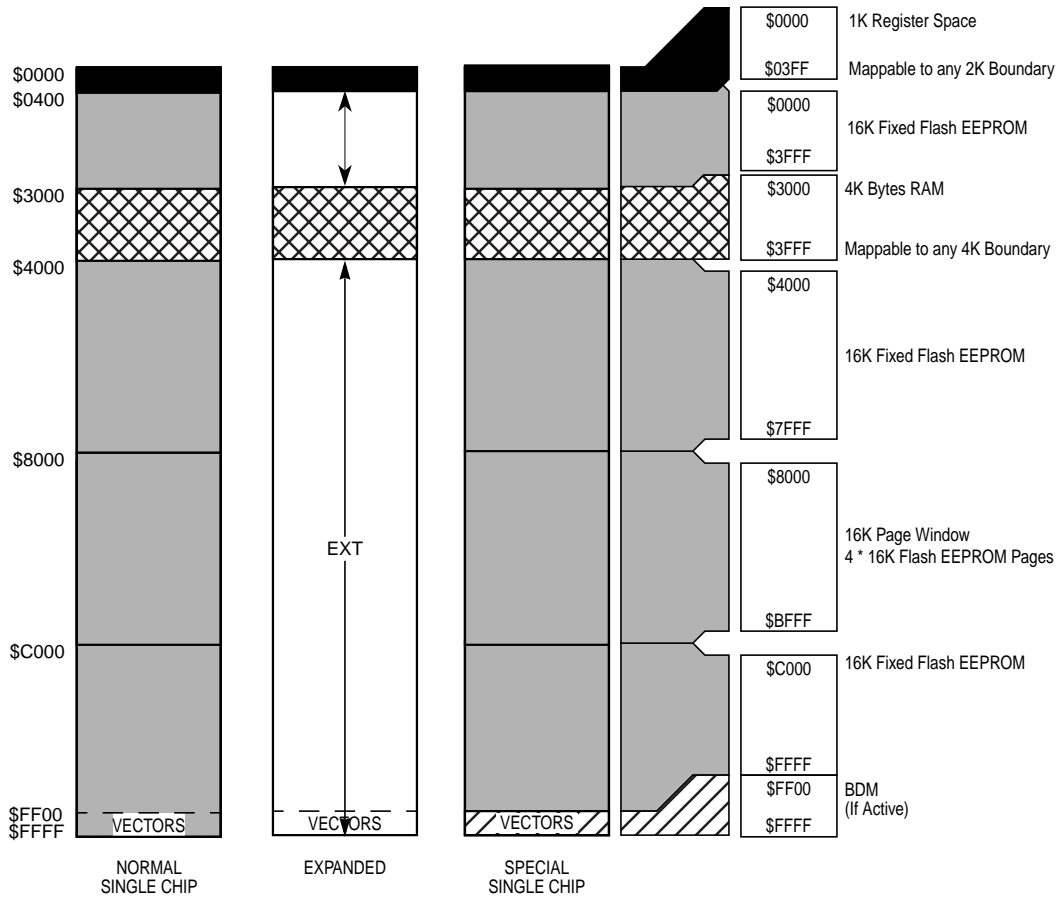

The figure shows a useful map, which is not the map out of reset. After reset the map is:

- \$0000 - \$03FF: Register Space
- \$0000 - \$0FFF: 4K RAM (only 3K visible \$0400 - \$0FFF)

Flash Erase Sector Size is 512 Bytes

**Figure 1-4 MC9S12C64 and MC9S12GC64 User Configurable Memory Map**

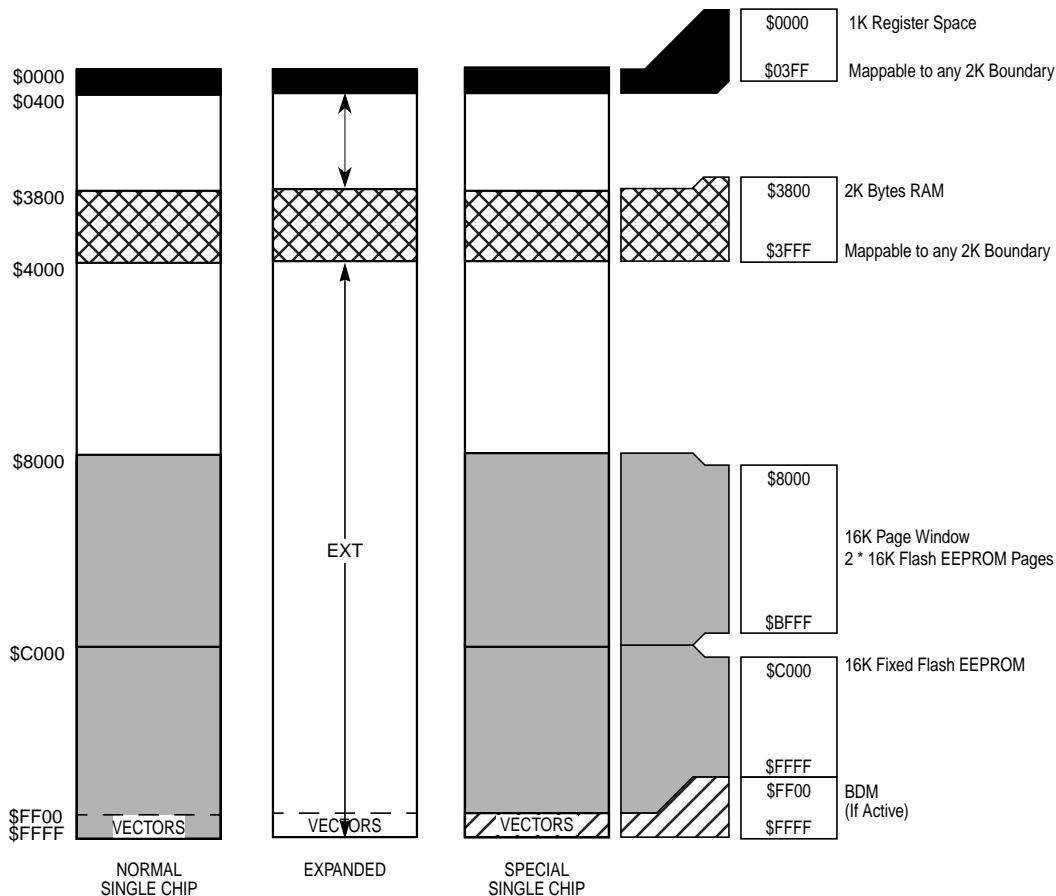

The figure shows a useful map, which is not the map out of reset. After reset the map is:

\$0000 - \$03FF: Register Space  
 \$0800 - \$0FFF: 2K RAM

Flash Erase Sector Size is 512 Bytes

**Figure 1-5 MC9S12C32 and MC9S12GC32 User Configurable Memory Map**

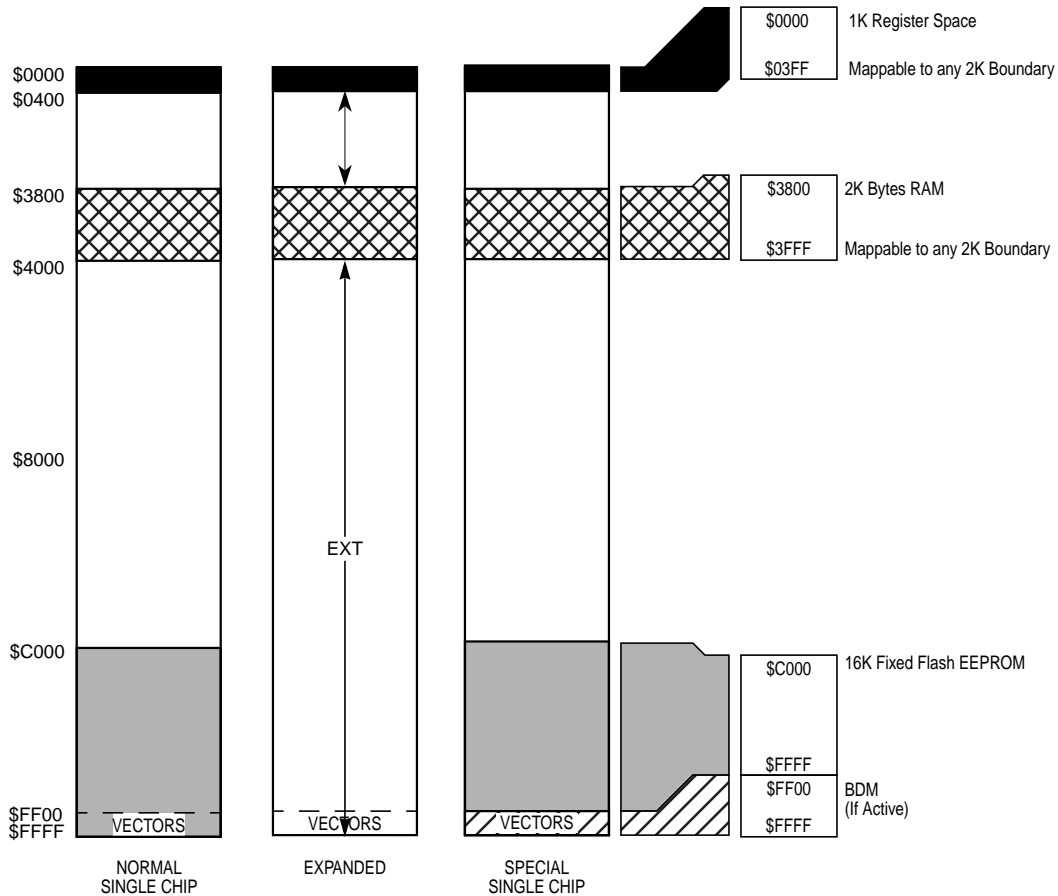

**Figure 1-6 MC9S12GC16 User Configurable Memory Map**

## 1.6 Detailed Register Map

The detailed register map of the MC9S12C Family is listed in address order below.

**\$0000 - \$000F**

**MEBI map 1 of 3 (HCS12 Multiplexed External Bus Interface)**

Address	Name		Bit 7	Bit 6	Bit 5	Bit 4	Bit 3	Bit 2	Bit 1	Bit 0
\$0000	PORTA	Read:	Bit 7	6	5	4	3	2	1	Bit 0
		Write:	Bit 7	6	5	4	3	2	1	Bit 0
\$0001	PORTB	Read:	Bit 7	6	5	4	3	2	1	Bit 0
		Write:	Bit 7	6	5	4	3	2	1	Bit 0
\$0002	DDRA	Read:	Bit 7	6	5	4	3	2	1	Bit 0
		Write:	Bit 7	6	5	4	3	2	1	Bit 0
\$0003	DDRB	Read:	Bit 7	6	5	4	3	2	1	Bit 0
		Write:	Bit 7	6	5	4	3	2	1	Bit 0
\$0004	Reserved	Read:	0	0	0	0	0	0	0	0
		Write:								
\$0005	Reserved	Read:	0	0	0	0	0	0	0	0
		Write:								
\$0006	Reserved	Read:	0	0	0	0	0	0	0	0
		Write:								
\$0007	Reserved	Read:	0	0	0	0	0	0	0	0
		Write:								
\$0008	PORTE	Read:	Bit 7	6	5	4	3	2	Bit 1	Bit 0
		Write:	Bit 7	6	5	4	3	2		
\$0009	DDRE	Read:	Bit 7	6	5	4	3	Bit 2	0	0
		Write:	Bit 7	6	5	4	3	Bit 2		
\$000A	PEAR	Read:	NOACCE	0	PIPOE	NECLK	LSTRE	RDWE	0	0
		Write:								
\$000B	MODE	Read:	MODC	MODB	MODA	0	IVIS	0	EMK	EME
		Write:								
\$000C	PUCR	Read:	PUPKE	0	0	PUPEE	0	0	PUPBE	PUPAE
		Write:								
\$000D	RDRIV	Read:	RDPK	0	0	RDPE	0	0	RDPB	RDPA
		Write:								
\$000E	EBICTL	Read:	0	0	0	0	0	0	0	ESTR
		Write:								
\$000F	Reserved	Read:	0	0	0	0	0	0	0	0
		Write:								

**\$0010 - \$0014**

**MMC map 1 of 4 (HCS12 Module Mapping Control)**

Address	Name		Bit 7	Bit 6	Bit 5	Bit 4	Bit 3	Bit 2	Bit 1	Bit 0
\$0010	INITRM	Read:	RAM15	RAM14	RAM13	RAM12	RAM11	0	0	RAMHAL
		Write:								
\$0011	INITRG	Read:	0	REG14	REG13	REG12	REG11	0	0	0
		Write:								
Address	Name		Bit 7	Bit 6	Bit 5	Bit 4	Bit 3	Bit 2	Bit 1	Bit 0

**\$0010 - \$0014**

**MMC map 1 of 4 (HCS12 Module Mapping Control)**

Address	Name	Bit 7	Bit 6	Bit 5	Bit 4	Bit 3	Bit 2	Bit 1	Bit 0
\$0012	INITEE	Read: EE15	EE14	EE13	EE12	EE11	0	0	EEON
		Write:							
\$0013	MISC	Read: 0	0	0	0	EXSTR1	EXSTR0	ROMHM	ROMON
		Write:							
\$0014	Reserved	Read: 0	0	0	0	0	0	0	0
		Write:							

**\$0015 - \$0016**

**INT map 1 of 2 (HCS12 Interrupt)**

Address	Name	Bit 7	Bit 6	Bit 5	Bit 4	Bit 3	Bit 2	Bit 1	Bit 0
\$0015	ITCR	Read: 0	0	0	WRINT	ADR3	ADR2	ADR1	ADR0
		Write:							
\$0016	ITEST	Read: INTE	INTC	INTA	INT8	INT6	INT4	INT2	INT0
		Write:							

**\$0017 - \$0017**

**MMC map 2 of 4 (HCS12 Module Mapping Control)**

Address	Name	Bit 7	Bit 6	Bit 5	Bit 4	Bit 3	Bit 2	Bit 1	Bit 0
\$0017	Reserved	Read: 0	0	0	0	0	0	0	0
		Write:							

**\$0018 - \$0018**

**Miscellaneous Peripherals (Device User Guide)**

Address	Name	Bit 7	Bit 6	Bit 5	Bit 4	Bit 3	Bit 2	Bit 1	Bit 0
\$0018	Reserved	Read: 0	0	0	0	0	0	0	0
		Write:							

**\$0019 - \$0019**

**VREG3V3 (Voltage Regulator)**

Address	Name	Bit 7	Bit 6	Bit 5	Bit 4	Bit 3	Bit 2	Bit 1	Bit 0
\$0019	VREGCTRL	Read: 0	0	0	0	0	LVDS	LVIE	LVIF
		Write:							

**\$001A - \$001B**

**Miscellaneous Peripherals (Device User Guide)**

Address	Name	Bit 7	Bit 6	Bit 5	Bit 4	Bit 3	Bit 2	Bit 1	Bit 0
\$001A	PARTIDH	Read: ID15	ID14	ID13	ID12	ID11	ID10	ID9	ID8
		Write:							
\$001B	PARTIDL	Read: ID7	ID6	ID5	ID4	ID3	ID2	ID1	ID0
		Write:							

**\$001C - \$001D**

**MMC map 3 of 4 (HCS12 Module Mapping Control, Device User Guide)**

Address	Name		Bit 7	Bit 6	Bit 5	Bit 4	Bit 3	Bit 2	Bit 1	Bit 0
\$001C	MEMSIZ0	Read:	reg_sw0	0	eep_sw1	eep_sw0	0	ram_sw2	ram_sw1	ram_sw0
		Write:								
\$001D	MEMSIZ1	Read:	rom_sw1	rom_sw0	0	0	0	0	pag_sw1	pag_sw0
		Write:								

**\$001E - \$001E**

**MEBI map 2 of 3 (HCS12 Multiplexed External Bus Interface)**

Address	Name		Bit 7	Bit 6	Bit 5	Bit 4	Bit 3	Bit 2	Bit 1	Bit 0
\$001E	INTCR	Read:	IRQE	IRQEN	0	0	0	0	0	0
		Write:								

**\$001F - \$001F**

**INT map 2 of 2 (HCS12 Interrupt)**

Address	Name		Bit 7	Bit 6	Bit 5	Bit 4	Bit 3	Bit 2	Bit 1	Bit 0
\$001F	HPRIO	Read:	PSEL7	PSEL6	PSEL5	PSEL4	PSEL3	PSEL2	PSEL1	0
		Write:								

**\$0020 - \$002F**

**DBG (including BKP) map 1 of 1 (HCS12 Debug)**

Address	Name		Bit 7	Bit 6	Bit 5	Bit 4	Bit 3	Bit 2	Bit 1	Bit 0
\$0020	DBGC1 -	read	DBGEN	ARM	TRGSEL	BEGIN	DBGBRK	0	CAPMOD	
		write								
\$0021	DBGSC -	read	AF	BF	CF	0	TRG			
		write								
\$0022	DBGTBH -	read	Bit 15	Bit 14	Bit 13	Bit 12	Bit 11	Bit 10	Bit 9	Bit 8
		write								
\$0023	DBGTBL -	read	Bit 7	Bit 6	Bit 5	Bit 4	Bit 3	Bit 2	Bit 1	Bit 0
		write								
\$0024	DBGCNT -	read	TBF	0	CNT					
		write								
\$0025	DBGCCX -	read	PAGSEL			EXTCMP				
		write								
\$0026	DBGCCH	read	Bit 15	14	13	12	11	10	9	Bit 8
		write								
\$0027	DBGCCL -	read	Bit 7	6	5	4	3	2	1	Bit 0
		write								
\$0028	DBGC2 BKPCT0	read	BKABEN	FULL	BDM	TAGAB	BKGEN	TAGC	RWCEN	RWC
		write								
\$0029	DBGC3 BKPCT1	read	BKAMBH	BKAMBL	BKBMBH	BKBMBL	RWAEN	RWA	RWBEN	RWB
		write								
\$002A	DBGCAH BKPOX	read	PAGSEL			EXTCMP				
		write								
\$002B	DBGCAH BKPOH	read	Bit 15	14	13	12	11	10	9	Bit 8
		write								

**\$0020 - \$002F**

**DBG (including BKP) map 1 of 1 (HCS12 Debug)**

Address	Name		Bit 7	Bit 6	Bit 5	Bit 4	Bit 3	Bit 2	Bit 1	Bit 0
\$002C	DBGCAL BKP0L	read write	Bit 7	6	5	4	3	2	1	Bit 0
\$002D	DBGCBX BKP1X	read write	PAGSEL			EXTCMP				
\$002E	DBGCBH BKP1H	read write	Bit 15	14	13	12	11	10	9	Bit 8
\$002F	DBGCBL BKP1L	read write	Bit 7	6	5	4	3	2	1	Bit 0

**\$0030 - \$0031**

**MMC map 4 of 4 (HCS12 Module Mapping Control)**

Address	Name		Bit 7	Bit 6	Bit 5	Bit 4	Bit 3	Bit 2	Bit 1	Bit 0
\$0030	PPAGE	Read: Write:	0	0	PIX5	PIX4	PIX3	PIX2	PIX1	PIX0
\$0031	Reserved	Read: Write:	0	0						

**\$0032 - \$0033**

**MEBI map 3 of 3 (HCS12 Multiplexed External Bus Interface)**

Address	Name		Bit 7	Bit 6	Bit 5	Bit 4	Bit 3	Bit 2	Bit 1	Bit 0
\$0032	PORTK <sup>1</sup>	Read: Write:	Bit 7	6	5	4	3	2	1	Bit 0
\$0033	DDRK <sup>(1)</sup>	Read: Write:	Bit 7	6	5	4	3	2	1	Bit 0

NOTES:

1. Only applicable in special emulation-only bond outs, for emulation of extended memory map.

**\$0034 - \$003F**

**CRG (Clock and Reset Generator)**

Address	Name		Bit 7	Bit 6	Bit 5	Bit 4	Bit 3	Bit 2	Bit 1	Bit 0
\$0034	SYNR	Read: Write:	0	0	SYN5	SYN4	SYN3	SYN2	SYN1	SYN0
\$0035	REFDV	Read: Write:	0	0						
\$0036	CTFLG TEST ONLY	Read: Write:	TOUT7	TOUT6	TOUT5	TOUT4	TOUT3	TOUT2	TOUT1	TOUT0
\$0037	CRGFLG	Read: Write:	RTIF	PROF	0	LOCKIF	LOCK	TRACK	SCMIF	SCM
\$0038	CRGINT	Read: Write:	RTIE	0	0	LOCKIE	0	0	SCMIE	0
\$0039	CLKSEL	Read: Write:	PLLSEL	PSTP	SYSWAI	ROAWAI	PLLWAI	CWAI	RTIWAI	COPWAI
\$003A	PLLCTL	Read: Write:	CME	PLLON	AUTO	ACQ	0	PRE	PCE	SCME

**\$0034 - \$003F**

**CRG (Clock and Reset Generator)**

Address	Name		Bit 7	Bit 6	Bit 5	Bit 4	Bit 3	Bit 2	Bit 1	Bit 0
\$003B	RTICTL	Read:	0	RTR6	RTR5	RTR4	RTR3	RTR2	RTR1	RTR0
		Write:								
\$003C	COPCTL	Read:	WCOP	RSBCK	0	0	0	CR2	CR1	CR0
		Write:								
\$003D	FORBYP TEST ONLY	Read:	RTIBYP	COPBYP	0	PLLBYP	0	0	FCM	0
		Write:								
\$003E	CTCTL TEST ONLY	Read:	TCTL7	TCTL6	TCTL5	TCTL4	TCTL3	TCTL2	TCTL1	TCTL0
		Write:								
\$003F	ARMCOP	Read:	0	0	0	0	0	0	0	0
		Write:	Bit 7	6	5	4	3	2	1	Bit 0

**\$0040 - \$006F**

**TIM (Timer 16 Bit 8 Channels)**

Address	Name		Bit 7	Bit 6	Bit 5	Bit 4	Bit 3	Bit 2	Bit 1	Bit 0
\$0040	TIOS	Read:	IOS7	IOS6	IOS5	IOS4	IOS3	IOS2	IOS1	IOS0
		Write:								
\$0041	CFORC	Read:	0	0	0	0	0	0	0	0
		Write:	FOC7	FOC6	FOC5	FOC4	FOC3	FOC2	FOC1	FOC0
\$0042	OC7M	Read:	OC7M7	OC7M6	OC7M5	OC7M4	OC7M3	OC7M2	OC7M1	OC7M0
		Write:								
\$0043	OC7D	Read:	OC7D7	OC7D6	OC7D5	OC7D4	OC7D3	OC7D2	OC7D1	OC7D0
		Write:								
\$0044	TCNT (hi)	Read:	Bit 15	14	13	12	11	10	9	Bit 8
		Write:								
\$0045	TCNT (lo)	Read:	Bit 7	6	5	4	3	2	1	Bit 0
		Write:								
\$0046	TSCR1	Read:	TEN	TSWAI	TSFRZ	TFFCA	0	0	0	0
		Write:								
\$0047	TTOV	Read:	TOV7	TOV6	TOV5	TOV4	TOV3	TOV2	TOV1	TOV0
		Write:								
\$0048	TCTL1	Read:	OM7	OL7	OM6	OL6	OM5	OL5	OM4	OL4
		Write:								
\$0049	TCTL2	Read:	OM3	OL3	OM2	OL2	OM1	OL1	OM0	OL0
		Write:								
\$004A	TCTL3	Read:	EDG7B	EDG7A	EDG6B	EDG6A	EDG5B	EDG5A	EDG4B	EDG4A
		Write:								
\$004B	TCTL4	Read:	EDG3B	EDG3A	EDG2B	EDG2A	EDG1B	EDG1A	EDG0B	EDG0A
		Write:								
\$004C	TIE	Read:	C7I	C6I	C5I	C4I	C3I	C2I	C1I	C0I
		Write:								
\$004D	TSCR2	Read:	TOI	0	0	0	TCRE	PR2	PR1	PR0
		Write:								
\$004E	TFLG1	Read:	C7F	C6F	C5F	C4F	C3F	C2F	C1F	C0F
		Write:								
\$004F	TFLG2	Read:	TOF	0	0	0	0	0	0	0
		Write:								

Address	Name		Bit 7	Bit 6	Bit 5	Bit 4	Bit 3	Bit 2	Bit 1	Bit 0
\$0050	TC0 (hi)	Read:	Bit 15	14	13	12	11	10	9	Bit 8
		Write:								
\$0051	TC0 (lo)	Read:	Bit 7	6	5	4	3	2	1	Bit 0
		Write:								
\$0052	TC1 (hi)	Read:	Bit 15	14	13	12	11	10	9	Bit 8
		Write:								
\$0053	TC1 (lo)	Read:	Bit 7	6	5	4	3	2	1	Bit 0
		Write:								
\$0054	TC2 (hi)	Read:	Bit 15	14	13	12	11	10	9	Bit 8
		Write:								
\$0055	TC2 (lo)	Read:	Bit 7	6	5	4	3	2	1	Bit 0
		Write:								
\$0056	TC3 (hi)	Read:	Bit 15	14	13	12	11	10	9	Bit 8
		Write:								
\$0057	TC3 (lo)	Read:	Bit 7	6	5	4	3	2	1	Bit 0
		Write:								
\$0058	TC4 (hi)	Read:	Bit 15	14	13	12	11	10	9	Bit 8
		Write:								
\$0059	TC4 (lo)	Read:	Bit 7	6	5	4	3	2	1	Bit 0
		Write:								
\$005A	TC5 (hi)	Read:	Bit 15	14	13	12	11	10	9	Bit 8
		Write:								
\$005B	TC5 (lo)	Read:	Bit 7	6	5	4	3	2	1	Bit 0
		Write:								
\$005C	TC6 (hi)	Read:	Bit 15	14	13	12	11	10	9	Bit 8
		Write:								
\$005D	TC6 (lo)	Read:	Bit 7	6	5	4	3	2	1	Bit 0
		Write:								
\$005E	TC7 (hi)	Read:	Bit 15	14	13	12	11	10	9	Bit 8
		Write:								
\$005F	TC7 (lo)	Read:	Bit 7	6	5	4	3	2	1	Bit 0
		Write:								
\$0060	PACTL	Read:	0	PAEN	PAMOD	PEDGE	CLK1	CLK0	PAOVI	PAI
		Write:								
\$0061	PAFLG	Read:	0	0	0	0	0	0	PAOVF	PAIF
		Write:								
\$0062	PACNT (hi)	Read:	Bit 15	14	13	12	11	10	9	Bit 8
		Write:								
\$0063	PACNT (lo)	Read:	Bit 7	6	5	4	3	2	1	Bit 0
		Write:								
\$0064	Reserved	Read:	0	0	0	0	0	0	0	0
		Write:								
\$0065	Reserved	Read:	0	0	0	0	0	0	0	0
		Write:								
\$0066	Reserved	Read:	0	0	0	0	0	0	0	0
		Write:								
\$0067	Reserved	Read:	0	0	0	0	0	0	0	0
		Write:								

Address	Name		Bit 7	Bit 6	Bit 5	Bit 4	Bit 3	Bit 2	Bit 1	Bit 0
\$0068	Reserved	Read:	0	0	0	0	0	0	0	0
		Write:								
\$0069	Reserved	Read:	0	0	0	0	0	0	0	0
		Write:								
\$006A	Reserved	Read:	0	0	0	0	0	0	0	0
		Write:								
\$006B	Reserved	Read:	0	0	0	0	0	0	0	0
		Write:								
\$006C	Reserved	Read:	0	0	0	0	0	0	0	0
		Write:								
\$006D	Reserved	Read:	0	0	0	0	0	0	0	0
		Write:								
\$006E	Reserved	Read:	0	0	0	0	0	0	0	0
		Write:								
\$006F	Reserved	Read:	0	0	0	0	0	0	0	0
		Write:								

**\$0070 - \$007F**

**Reserved**

\$0070 - \$007F	Reserved	Read:	0	0	0	0	0	0	0	0
		Write:								

**\$0080 - \$009F**

**ATD (Analog to Digital Converter 10 Bit 8 Channel)**

Address	Name		Bit 7	Bit 6	Bit 5	Bit 4	Bit 3	Bit 2	Bit 1	Bit 0
\$0080	ATDCTL0	Read:	0	0	0	0	0	0	0	0
		Write:								
\$0081	ATDCTL1	Read:	0	0	0	0	0	0	0	0
		Write:								
\$0082	ATDCTL2	Read:	ADPU	AFFC	AWAI	ETRIGLE	ETRIGP	ETRIG	ASCIE	ASCIF
		Write:								
\$0083	ATDCTL3	Read:	0	S8C	S4C	S2C	S1C	FIFO	FRZ1	FRZ0
		Write:								
\$0084	ATDCTL4	Read:	SRES8	SMP1	SMP0	PRS4	PRS3	PRS2	PRS1	PRS0
		Write:								
\$0085	ATDCTL5	Read:	DJM	DSGN	SCAN	MULT	0	CC	CB	CA
		Write:								
\$0086	ATDSTAT0	Read:	SCF	0	ETORF	FIFOR	0	CC2	CC1	CC0
		Write:								
\$0087	Reserved	Read:	0	0	0	0	0	0	0	0
		Write:								
\$0088	ATDTEST0	Read:	0	0	0	0	0	0	0	0
		Write:								
\$0089	ATDTEST1	Read:	0	0	0	0	0	0	0	SC
		Write:								
\$008A	Reserved	Read:	0	0	0	0	0	0	0	0
		Write:								

**\$0080 - \$009F**

**ATD (Analog to Digital Converter 10 Bit 8 Channel)**

Address	Name		Bit 7	Bit 6	Bit 5	Bit 4	Bit 3	Bit 2	Bit 1	Bit 0
\$008B	ATDSTAT1	Read:	CCF7	CCF6	CCF5	CCF4	CCF3	CCF2	CCF1	CCF0
		Write:								
\$008C	Reserved	Read:	0	0	0	0	0	0	0	0
		Write:								
\$008D	ATDDIEN	Read:	Bit 7	6	5	4	3	2	1	Bit 0
		Write:								
\$008E	Reserved	Read:	0	0	0	0	0	0	0	0
		Write:								
\$008F	PORTAD0	Read:	Bit7	6	5	4	3	2	1	BIT 0
		Write:								
\$0090	ATDDR0H	Read:	Bit15	14	13	12	11	10	9	Bit8
		Write:								
\$0091	ATDDR0L	Read:	Bit7	Bit6	0	0	0	0	0	0
		Write:								
\$0092	ATDDR1H	Read:	Bit15	14	13	12	11	10	9	Bit8
		Write:								
\$0093	ATDDR1L	Read:	Bit7	Bit6	0	0	0	0	0	0
		Write:								
\$0094	ATDDR2H	Read:	Bit15	14	13	12	11	10	9	Bit8
		Write:								
\$0095	ATDDR2L	Read:	Bit7	Bit6	0	0	0	0	0	0
		Write:								
\$0096	ATDDR3H	Read:	Bit15	14	13	12	11	10	9	Bit8
		Write:								
\$0097	ATDDR3L	Read:	Bit7	Bit6	0	0	0	0	0	0
		Write:								
\$0098	ATDDR4H	Read:	Bit15	14	13	12	11	10	9	Bit8
		Write:								
\$0099	ATDDR4L	Read:	Bit7	Bit6	0	0	0	0	0	0
		Write:								
\$009A	ATDDR5H	Read:	Bit15	14	13	12	11	10	9	Bit8
		Write:								
\$009B	ATDDR5L	Read:	Bit7	Bit6	0	0	0	0	0	0
		Write:								
\$009C	ATDDR6H	Read:	Bit15	14	13	12	11	10	9	Bit8
		Write:								
\$009D	ATDDR6L	Read:	Bit7	Bit6	0	0	0	0	0	0
		Write:								
\$009E	ATDDR7H	Read:	Bit15	14	13	12	11	10	9	Bit8
		Write:								
\$009F	ATDDR7L	Read:	Bit7	Bit6	0	0	0	0	0	0
		Write:								

**\$00A0 - \$00C7**

**Reserved**

\$00A0 - \$00C7	Reserved	Read:	0	0	0	0	0	0	0	0
		Write:								

**\$00C8 - \$00CF**

**SCI (Asynchronous Serial Interface)**

Address	Name		Bit 7	Bit 6	Bit 5	Bit 4	Bit 3	Bit 2	Bit 1	Bit 0
\$00C8	SCIBDH	Read:	0	0	0	SBR12	SBR11	SBR10	SBR9	SBR8
		Write:								
\$00C9	SCIBDL	Read:	SBR7	SBR6	SBR5	SBR4	SBR3	SBR2	SBR1	SBR0
		Write:								
\$00CA	SCICR1	Read:	LOOPS	SCISWAI	RSRC	M	WAKE	ILT	PE	PT
		Write:								
\$00CB	SCICR2	Read:	TIE	TCIE	RIE	ILIE	TE	RE	RWU	SBK
		Write:								
\$00CC	SCISR1	Read:	TDRE	TC	RDRF	IDLE	OR	NF	FE	PF
		Write:								
\$00CD	SCISR2	Read:	0	0	0	0	0	BRK13	TXDIR	RAF
		Write:								
\$00CE	SCIDRH	Read:	R8	T8	0	0	0	0	0	0
		Write:								
\$00CF	SCIDRL	Read:	R7	R6	R5	R4	R3	R2	R1	R0
		Write:	T7	T6	T5	T4	T3	T2	T1	T0

**\$00D0 - \$00D7**

**Reserved**

\$00D0	Reserved	Read:	0	0	0	0	0	0	0	0
-\$00D7		Write:								

**\$00D8 - \$00DF**

**SPI (Serial Peripheral Interface)**

Address	Name		Bit 7	Bit 6	Bit 5	Bit 4	Bit 3	Bit 2	Bit 1	Bit 0
\$00D8	SPICR1	Read:	SPIE	SPE	SPTIE	MSTR	CPOL	CPHA	SSOE	LSBFE
		Write:								
\$00D9	SPICR2	Read:	0	0	0	MODFEN	BIDIROE	0	SPISWAI	SPC0
		Write:								
\$00DA	SPIBR	Read:	0	SPPR2	SPPR1	SPPR0	0	SPR2	SPR1	SPR0
		Write:								
\$00DB	SPISR	Read:	SPIF	0	SPTEF	MODF	0	0	0	0
		Write:								
\$00DC	Reserved	Read:	0	0	0	0	0	0	0	0
		Write:								
\$00DD	SPIDR	Read:	Bit7	6	5	4	3	2	1	Bit0
		Write:								
\$00DE	Reserved	Read:	0	0	0	0	0	0	0	0
		Write:								
\$00DF	Reserved	Read:	0	0	0	0	0	0	0	0
		Write:								

**\$00E0 - \$00FF**

**PWM (Pulse Width Modulator)**

Address	Name		Bit 7	Bit 6	Bit 5	Bit 4	Bit 3	Bit 2	Bit 1	Bit 0
\$00E0	PWME	Read:	0	0	PWME5	PWME4	PWME3	PWME2	PWME1	PWME0
		Write:								
\$00E1	PWMPOL	Read:	0	0	PPOL5	PPOL4	PPOL3	PPOL2	PPOL1	PPOL0
		Write:								
\$00E2	PWMCLK	Read:	0	0	PCLK5	PCLK4	PCLK3	PCLK2	PCLK1	PCLK0
		Write:								
\$00E3	PWMPRCLK	Read:	0	PCKB2	PCKB1	PCKB0	0	PCKA2	PCKA1	PCKA0
		Write:								
\$00E4	PWMCAE	Read:	0	0	CAE5	CAE4	CAE3	CAE2	CAE1	CAE0
		Write:								
\$00E5	PWMCTL	Read:	0	CON45	CON23	CON01	PSWAI	PFRZ	0	0
		Write:								
\$00E6	PWMTST Test Only	Read:	0	0	0	0	0	0	0	0
		Write:								
\$00E7	PWMPRSC	Read:	0	0	0	0	0	0	0	0
		Write:								
\$00E8	PWMSCLA	Read:	Bit 7	6	5	4	3	2	1	Bit 0
		Write:								
\$00E9	PWMSCLB	Read:	Bit 7	6	5	4	3	2	1	Bit 0
		Write:								
\$00EA	PWMSCNTA	Read:	0	0	0	0	0	0	0	0
		Write:								
\$00EB	PWMSCNTB	Read:	0	0	0	0	0	0	0	0
		Write:								
\$00EC	PWMCNT0	Read:	Bit 7	6	5	4	3	2	1	Bit 0
		Write:	0	0	0	0	0	0	0	0
\$00ED	PWMCNT1	Read:	Bit 7	6	5	4	3	2	1	Bit 0
		Write:	0	0	0	0	0	0	0	0
\$00EE	PWMCNT2	Read:	Bit 7	6	5	4	3	2	1	Bit 0
		Write:	0	0	0	0	0	0	0	0
\$00EF	PWMCNT3	Read:	Bit 7	6	5	4	3	2	1	Bit 0
		Write:	0	0	0	0	0	0	0	0
\$00F0	PWMCNT4	Read:	Bit 7	6	5	4	3	2	1	Bit 0
		Write:	0	0	0	0	0	0	0	0
\$00F1	PWMCNT5	Read:	Bit 7	6	5	4	3	2	1	Bit 0
		Write:	0	0	0	0	0	0	0	0
\$00F2	PWMPER0	Read:	Bit 7	6	5	4	3	2	1	Bit 0
		Write:								
\$00F3	PWMPER1	Read:	Bit 7	6	5	4	3	2	1	Bit 0
		Write:								
\$00F4	PWMPER2	Read:	Bit 7	6	5	4	3	2	1	Bit 0
		Write:								
\$00F5	PWMPER3	Read:	Bit 7	6	5	4	3	2	1	Bit 0
		Write:								
\$00F6	PWMPER4	Read:	Bit 7	6	5	4	3	2	1	Bit 0
		Write:								

Address	Name		Bit 7	Bit 6	Bit 5	Bit 4	Bit 3	Bit 2	Bit 1	Bit 0
\$00F7	PWMPER5	Read:	Bit 7	6	5	4	3	2	1	Bit 0
		Write:								
\$00F8	PWMDTY0	Read:	Bit 7	6	5	4	3	2	1	Bit 0
		Write:								
\$00F9	PWMDTY1	Read:	Bit 7	6	5	4	3	2	1	Bit 0
		Write:								
\$00FA	PWMDTY2	Read:	Bit 7	6	5	4	3	2	1	Bit 0
		Write:								
\$00FB	PWMDTY3	Read:	Bit 7	6	5	4	3	2	1	Bit 0
		Write:								
\$00FC	PWMDTY4	Read:	Bit 7	6	5	4	3	2	1	Bit 0
		Write:								
\$00FD	PWMDTY5	Read:	Bit 7	6	5	4	3	2	1	Bit 0
		Write:								
\$00FE	Reserved	Read:	0	0	0	0	0	0	0	0
		Write:								
\$00FF	Reserved	Read:	0	0	0	0	0	0	0	0
		Write:								

**\$0100 - \$010F**

**Flash Control Register**

Address	Name		Bit 7	Bit 6	Bit 5	Bit 4	Bit 3	Bit 2	Bit 1	Bit 0
\$0100	FCLKDIV	Read:	FDIVLD	PRDIV8	FDIV5	FDIV4	FDIV3	FDIV2	FDIV1	FDIV0
		Write:								
\$0101	FSEC	Read:	KEYEN1	KEYEN0	NV5	NV4	NV3	NV2	SEC1	SEC0
		Write:								
\$0102	FTSTMOD	Read:	0	0	0	WRALL	0	0	0	0
		Write:								
\$0103	FCNFG	Read:	CBEIE	CCIE	KEYACC	0	0	0	BKSEL1	BKSEL0
		Write:								
\$0104	FPROT	Read:	FPOPEN	NV6	FPHDIS	FPHS1	FPHS0	FPLDIS	FPLS1	FPLS0
		Write:								
\$0105	FSTAT	Read:	CBEIF	CCIF	PVIOL	ACCERR	0	BLANK	0	0
		Write:								
\$0106	FCMD	Read:	0	CMDB6	CMDB5	0	0	CMDB2	0	CMDB0
		Write:								
\$0107	Reserved for Factory Test	Read:	0	0	0	0	0	0	0	0
		Write:								
\$0108	Reserved for Factory Test	Read:	0	0	0	0	0	0	0	0
		Write:								
\$0109	Reserved for Factory Test	Read:	0	0	0	0	0	0	0	0
		Write:								
\$010A	Reserved for Factory Test	Read:	0	0	0	0	0	0	0	0
		Write:								
\$010B	Reserved for Factory Test	Read:	0	0	0	0	0	0	0	0
		Write:								

**\$0100 - \$010F**

**Flash Control Register**

Address	Name		Bit 7	Bit 6	Bit 5	Bit 4	Bit 3	Bit 2	Bit 1	Bit 0
\$010C	Reserved	Read:	0	0	0	0	0	0	0	0
		Write:								
\$010D	Reserved	Read:	0	0	0	0	0	0	0	0
		Write:								
\$010E	Reserved	Read:	0	0	0	0	0	0	0	0
		Write:								
\$010F	Reserved	Read:	0	0	0	0	0	0	0	0
		Write:								

**\$0110 - \$013F**

**Reserved**

\$0110 - \$003F	Reserved	Read:	0	0	0	0	0	0	0	0
		Write:								

**\$0140 - \$017F**

**CAN (Motorola Scalable CAN - MSCAN)<sup>1</sup>**

Address	Name		Bit 7	Bit 6	Bit 5	Bit 4	Bit 3	Bit 2	Bit 1	Bit 0
\$0140	CANCTL0	Read:	RXFRM	RXACT	CSWAI	SYNCH	TIME	WUPE	SLPRQ	INITRQ
		Write:								
\$0141	CANCTL1	Read:	CANE	CLKSRC	LOOPB	LISTEN	0	WUPM	SLPAK	INITAK
		Write:								
\$0142	CANBTR0	Read:	SJW1	SJW0	BRP5	BRP4	BRP3	BRP2	BRP1	BRP0
		Write:								
\$0143	CANBTR1	Read:	SAMP	TSEG22	TSEG21	TSEG20	TSEG13	TSEG12	TSEG11	TSEG10
		Write:								
\$0144	CANRFLG	Read:	WUPIF	CSCIF	RSTAT1	RSTAT0	TSTAT1	TSTAT0	OVRIF	RXF
		Write:								
\$0145	CANRIER	Read:	WUPIE	CSCIE	RSTATE1	RSTATE0	TSTATE1	TSTATE0	OVRIE	RXFIE
		Write:								
\$0146	CANTFLG	Read:	0	0	0	0	0	TXE2	TXE1	TXE0
		Write:								
\$0147	CANTIER	Read:	0	0	0	0	0	TXEIE2	TXEIE1	TXEIE0
		Write:								
\$0148	CANTARQ	Read:	0	0	0	0	0	ABTRQ2	ABTRQ1	ABTRQ0
		Write:								
\$0149	CANTAACK	Read:	0	0	0	0	0	ABTAK2	ABTAK1	ABTAK0
		Write:								
\$014A	CANTBSEL	Read:	0	0	0	0	0	TX2	TX1	TX0
		Write:								
\$014B	CANIDAC	Read:	0	0	IDAM1	IDAM0	0	IDHIT2	IDHIT1	IDHIT0
		Write:								
\$014C	Reserved	Read:	0	0	0	0	0	0	0	0
		Write:								
\$014D	Reserved	Read:	0	0	0	0	0	0	0	0
		Write:								

**\$0140 - \$017F**

**CAN (Motorola Scalable CAN - MSCAN)<sup>1</sup>**

Address	Name		Bit 7	Bit 6	Bit 5	Bit 4	Bit 3	Bit 2	Bit 1	Bit 0
\$014E	CANRXERR	Read:	RXERR7	RXERR6	RXERR5	RXERR4	RXERR3	RXERR2	RXERR1	RXERR0
		Write:								
\$014F	CANTXERR	Read:	TXERR7	TXERR6	TXERR5	TXERR4	TXERR3	TXERR2	TXERR1	TXERR0
		Write:								
\$0150 - \$0153	CANIDAR0 - CANIDAR3	Read:	AC7	AC6	AC5	AC4	AC3	AC2	AC1	AC0
		Write:								
\$0154 - \$0157	CANIDMR0 - CANIDMR3	Read:	AM7	AM6	AM5	AM4	AM3	AM2	AM1	AM0
		Write:								
\$0158 - \$015B	CANIDAR4 - CANIDAR7	Read:	AC7	AC6	AC5	AC4	AC3	AC2	AC1	AC0
		Write:								
\$015C - \$015F	CANIDMR4 - CANIDMR7	Read:	AM7	AM6	AM5	AM4	AM3	AM2	AM1	AM0
		Write:								
\$0160 - \$016F	CANRXFG	Read:	FOREGROUND RECEIVE BUFFER see <b>Table 1-2</b>							
		Write:								
\$0170 - \$017F	CANTXFG	Read:	FOREGROUND TRANSMIT BUFFER see <b>Table 1-2</b>							
		Write:								

NOTES:

1. Not available on the MC9S12GC-Family members. Those memory locations should not be accessed.

**Table 1-2 Detailed MSCAN Foreground Receive and Transmit Buffer Layout**

Address	Name		Bit 7	Bit 6	Bit 5	Bit 4	Bit 3	Bit 2	Bit 1	Bit 0
\$xxx0	Extended ID	Read:	ID28	ID27	ID26	ID25	ID24	ID23	ID22	ID21
		Write:								
\$xxx1	Standard ID	Read:	ID10	ID9	ID8	ID7	ID6	ID5	ID4	ID3
		Write:								
\$xxx1	Extended ID	Read:	ID20	ID19	ID18	SRR=1	IDE=1	ID17	ID16	ID15
		Write:								
\$xxx2	Standard ID	Read:	ID2	ID1	ID0	RTR	IDE=0			
		Write:								
\$xxx2	Extended ID	Read:	ID14	ID13	ID12	ID11	ID10	ID9	ID8	ID7
		Write:								
\$xxx3	Standard ID	Read:	ID6	ID5	ID4	ID3	ID2	ID1	ID0	RTR
		Write:								
\$xxx4- \$xxxB	CANxRDSR0 - CANxRDSR7	Read:	DB7	DB6	DB5	DB4	DB3	DB2	DB1	DB0
		Write:								
\$xxxC	CANRxDLR	Read:					DLC3	DLC2	DLC1	DLC0
		Write:								
\$xxxD	Reserved	Read:								
		Write:								
\$xxxE	CANxRTSRH	Read:	TSR15	TSR14	TSR13	TSR12	TSR11	TSR10	TSR9	TSR8
		Write:								
\$xxxF	CANxRTSRL	Read:	TSR7	TSR6	TSR5	TSR4	TSR3	TSR2	TSR1	TSR0
		Write:								
\$xx10	Extended ID	Read:	ID28	ID27	ID26	ID25	ID24	ID23	ID22	ID21
		Write:								
	Standard ID	Read:	ID10	ID9	ID8	ID7	ID6	ID5	ID4	ID3
		Write:								

Address	Name		Bit 7	Bit 6	Bit 5	Bit 4	Bit 3	Bit 2	Bit 1	Bit 0
\$xx11	Extended ID CANxTIDR1	Read:	ID20	ID19	ID18	SRR=1	IDE=1	ID17	ID16	ID15
		Write:								
	Standard ID	Read:	ID2	ID1	ID0	RTR	IDE=0			
		Write:								
\$xx12	Extended ID CANxTIDR2	Read:	ID14	ID13	ID12	ID11	ID10	ID9	ID8	ID7
		Write:								
	Standard ID	Read:								
		Write:								
\$xx13	Extended ID CANxTIDR3	Read:	ID6	ID5	ID4	ID3	ID2	ID1	ID0	RTR
		Write:								
	Standard ID	Read:								
		Write:								
\$xx14- \$xx1B	CANxTDSR0 - CANxTDSR7	Read:	DB7	DB6	DB5	DB4	DB3	DB2	DB1	DB0
		Write:								
\$xx1C	CANxTDLR	Read:					DLC3	DLC2	DLC1	DLC0
		Write:								
\$xx1D	CONxTTBPR	Read:	PRI07	PRI06	PRI05	PRI04	PRI03	PRI02	PRI01	PRI00
		Write:								
\$xx1E	CANxTTSRH	Read:	TSR15	TSR14	TSR13	TSR12	TSR11	TSR10	TSR9	TSR8
		Write:								
\$xx1F	CANxTTSRL	Read:	TSR7	TSR6	TSR5	TSR4	TSR3	TSR2	TSR1	TSR0
		Write:								

**\$0180 - \$023F**

\$0180  
- \$023F Reserved

**Reserved**

Read:	0	0	0	0	0	0	0	0
Write:								

**\$0240 - \$027F**

**PIM (Port Interface Module)**

\$0240	PTT	Read:	PTT7	PTT6	PTT5	PTT4	PTT3	PTT2	PTT1	PTT0
		Write:								
\$0241	PTIT	Read:	PTIT7	PTIT6	PTIT5	PTIT4	PTIT3	PTIT2	PTIT1	PTIT0
		Write:								
\$0242	DDRT	Read:	DDRT7	DDRT6	DDRT5	DDRT4	DDRT3	DDRT2	DDRT1	DDRT0
		Write:								
\$0243	RDRT	Read:	RDRT7	RDRT6	RDRT5	RDRT4	RDRT3	RDRT2	RDRT1	RDRT0
		Write:								
\$0244	PERT	Read:	PERT7	PERT6	PERT5	PERT4	PERT3	PERT2	PERT1	PERT0
		Write:								
\$0245	PPST	Read:	PPST7	PPST6	PPST5	PPST4	PPST3	PPST2	PPST1	PPST0
		Write:								
\$0246	Reserved	Read:	0	0	0	0	0	0	0	0
		Write:								
\$0247	MODRR	Read:	0	0	0	MODRR4	MODRR3	MODRR2	MODRR1	MODRR0
		Write:								
\$0248	PTS	Read:	0	0	0	0	PTS3	PTS2	PTS1	PTS0
		Write:								

\$0249	PTIS	Read:	0	0	0	0	PTIS3	PTIS2	PTIS1	PTIS0
		Write:								
\$024A	DDRS	Read:	0	0	0	0	DDRS3	DDRS2	DDRS1	DDRS0
		Write:								
\$024B	RDRS	Read:	0	0	0	0	RDRS3	RDRS2	RDRS1	RDRS0
		Write:								
\$024C	PERS	Read:	0	0	0	0	PERS3	PERS2	PERS1	PERS0
		Write:								
\$024D	PPSS	Read:	0	0	0	0	PPSS3	PPSS2	PPSS1	PPSS0
		Write:								
\$024E	WOMS	Read:	0	0	0	0	WOMS3	WOMS2	WOMS1	WOMS0
		Write:								
\$024F	Reserved	Read:	0	0	0	0	0	0	0	0
		Write:								
\$0250	PTM	Read:	0	0	PTM5	PTM4	PTM3	PTM2	PTM1	PTM0
		Write:								
\$0251	PTIM	Read:	0	0	PTIM5	PTIM4	PTIM3	PTIM2	PTIM1	PTIM0
		Write:								
\$0252	DDRM	Read:	0	0	DDRM5	DDRM4	DDRM3	DDRM2	DDRM1	DDRM0
		Write:								
\$0253	RDRM	Read:	0	0	RDRM5	RDRM4	RDRM3	RDRM2	RDRM1	RDRM0
		Write:								
\$0254	PERM	Read:	0	0	PERM5	PERM4	PERM3	PERM2	PERM1	PERM0
		Write:								
\$0255	PPSM	Read:	0	0	PPSM5	PPSM4	PPSM3	PPSM2	PPSM1	PPSM0
		Write:								
\$0256	WOMM	Read:	0	0	WOMM5	WOMM4	WOMM3	WOMM2	WOMM1	WOMM0
		Write:								
\$0257	Reserved	Read:	0	0	0	0	0	0	0	0
		Write:								
\$0258	PTP	Read:	PTP7	PTP6	PTP5	PTP4	PTP3	PTP2	PTP1	PTP0
		Write:								
\$0259	PTIP	Read:	PTIP7	PTIP6	PTIP5	PTIP4	PTIP3	PTIP2	PTIP1	PTIP0
		Write:								
\$025A	DDRP	Read:	DDRP7	DDRP6	DDRP5	DDRP4	DDRP3	DDRP2	DDRP1	DDRP0
		Write:								
\$025B	RDRP	Read:	RDRP7	RDRP6	RDRP5	RDRP4	RDRP3	RDRP2	RDRP1	RDRP0
		Write:								
\$025C	PERP	Read:	PERP7	PERP6	PERP5	PERP4	PERP3	PERP2	PERP1	PERP0
		Write:								
\$025D	PPSP	Read:	PPSP7	PPSP6	PPSP5	PPSP4	PPSP3	PPSP2	PPSP1	PPSP0
		Write:								
\$025E	PIEP	Read:	PIEP7	PIEP6	PIEP5	PIEP4	PIEP3	PIEP2	PIEP1	PIEP0
		Write:								
\$025F	PIFP	Read:	PIFP7	PIFP6	PIFP5	PIFP4	PIFP3	PIFP2	PIFP1	PIFP0
		Write:								
\$0260	Reserved	Read:	0	0	0	0	0	0	0	0
		Write:								

\$0261	Reserved	Read:	0	0	0	0	0	0	0	
		Write:								
\$0262	Reserved	Read:	0	0	0	0	0	0	0	
		Write:								
\$0263	Reserved	Read:	0	0	0	0	0	0	0	
		Write:								
\$0264	Reserved	Read:	0	0	0	0	0	0	0	
		Write:								
\$0265	Reserved	Read:	0	0	0	0	0	0	0	
		Write:								
\$0266	Reserved	Read:	0	0	0	0	0	0	0	
		Write:								
\$0267	Reserved	Read:	0	0	0	0	0	0	0	
		Write:								
\$0268	PTJ	Read:	PTJ7	PTJ6	0	0	0	0	0	
		Write:								
\$0269	PTIJ	Read:	PTIJ7	PTIJ6	0	0	0	0	0	
		Write:								
\$026A	DDRJ	Read:	DDRJ7	DDRJ6	0	0	0	0	0	
		Write:								
\$026B	RDRJ	Read:	RDRJ7	RDRJ6	0	0	0	0	0	
		Write:								
\$026C	PERJ	Read:	PERJ7	PERJ6	0	0	0	0	0	
		Write:								
\$026D	PPSJ	Read:	PPSJ7	PPSJ6	0	0	0	0	0	
		Write:								
\$026E	PIEJ	Read:	PIEJ7	PIEJ6	0	0	0	0	0	
		Write:								
\$026F	PIFJ	Read:	PIFJ7	PIFJ6	0	0	0	0	0	
		Write:								
\$0270	PTAD	Read:	PTAD7	PTAD6	PTAD5	PTAD4	PTAD3	PTAD2	PTAD1	PTAD0
		Write:								
\$0271	PTIAD	Read:	PTIAD7	PTIAD6	PTIAD5	PTIAD4	PTIAD3	PTIAD2	PTIAD1	PTIJ7
		Write:								
\$0272	DDRAD	Read:	DDRAD7	DDRAD6	DDRAD5	DDRAD4	DDRAD3	DDRAD2	DDRAD1	DDRAD0
		Write:								
\$0273	RDRAD	Read:	RDRAD7	RDRAD6	RDRAD5	RDRAD4	RDRAD3	RDRAD2	RDRAD1	RDRAD0
		Write:								
\$0274	PERAD	Read:	PERAD7	PERAD6	PERAD5	PERAD4	PERAD3	PERAD2	PERAD1	PERAD0
		Write:								
\$0275	PPSAD	Read:	PPSAD7	PPSAD6	PPSAD5	PPSAD4	PPSAD3	PPSAD2	PPSAD1	PPSAD0
		Write:								
\$0276-\$027F	Reserved	Read:	0	0	0	0	0	0	0	
		Write:								

**\$0280 - \$03FF**

**Reserved space**

Address	Name		Bit 7	Bit 6	Bit 5	Bit 4	Bit 3	Bit 2	Bit 1	Bit 0
\$0280 - \$2FF	Reserved	Read:	0	0	0	0	0	0	0	0
		Write:								
\$0300 - \$03FF	Unimplemented	Read:	0	0	0	0	0	0	0	0
		Write:								

## 1.7 Part ID Assignments

The part ID is located in two 8-bit registers PARTIDH and PARTIDL (addresses \$001A and \$001B after reset). The read-only value is a unique part ID for each revision of the chip. Table 1-3 shows the assigned part ID numbers.

**Table 1-3 Assigned Part ID Numbers**

Device	Mask Set Number	Part ID <sup>1</sup>
MC9S12C32	0L45J	\$3300
MC9S12C32	1L45J	\$3300
MC9S12C32	2L45J	\$3302
MC9S12C64	TBD	TBD
MC9S12C96	TBD	TBD
MC9S12C128	0L09S	\$3100
MC9S12C128	1L09S	\$3101
MC9S12GC16	TBD	TBD
MC9S12GC32	TBD	TBD
MC9S12GC64	TBD	TBD
MC9S12GC128	TBD	TBD

NOTES:

- The coding is as follows:  
 Bit 15-12: Major family identifier  
 Bit 11-8: Minor family identifier  
 Bit 7-4: Major mask set revision number including FAB transfers  
 Bit 3-0: Minor - non full - mask set revision

The device memory sizes are located in two 8-bit registers MEMSIZ0 and MEMSIZ1 (addresses \$001C and \$001D after reset). **Table 1-4** shows the read-only values of these registers. Refer to Module Mapping and Control (MMC) Block Guide for further details.

**Table 1-4 Memory size registers**

Device	Register name	Value
MC9S12GC16	MEMSIZ0	\$00
	MEMSIZ1	\$80

**Table 1-4 Memory size registers**

Device	Register name	Value
MC9S12C32, MC9S12GC32	MEMSIZ0	\$00
	MEMSIZ1	\$80
MC9S12C64, MC9S12GC64	MEMSIZ0	\$01
	MEMSIZ1	\$C0
MC9S12C96	MEMSIZ0	\$01
	MEMSIZ1	\$C0
MC9S12C128, MC9S12GC128	MEMSIZ0	\$01
	MEMSIZ1	\$C0

# Section 2 Signal Description

## 2.1 Device Pinout

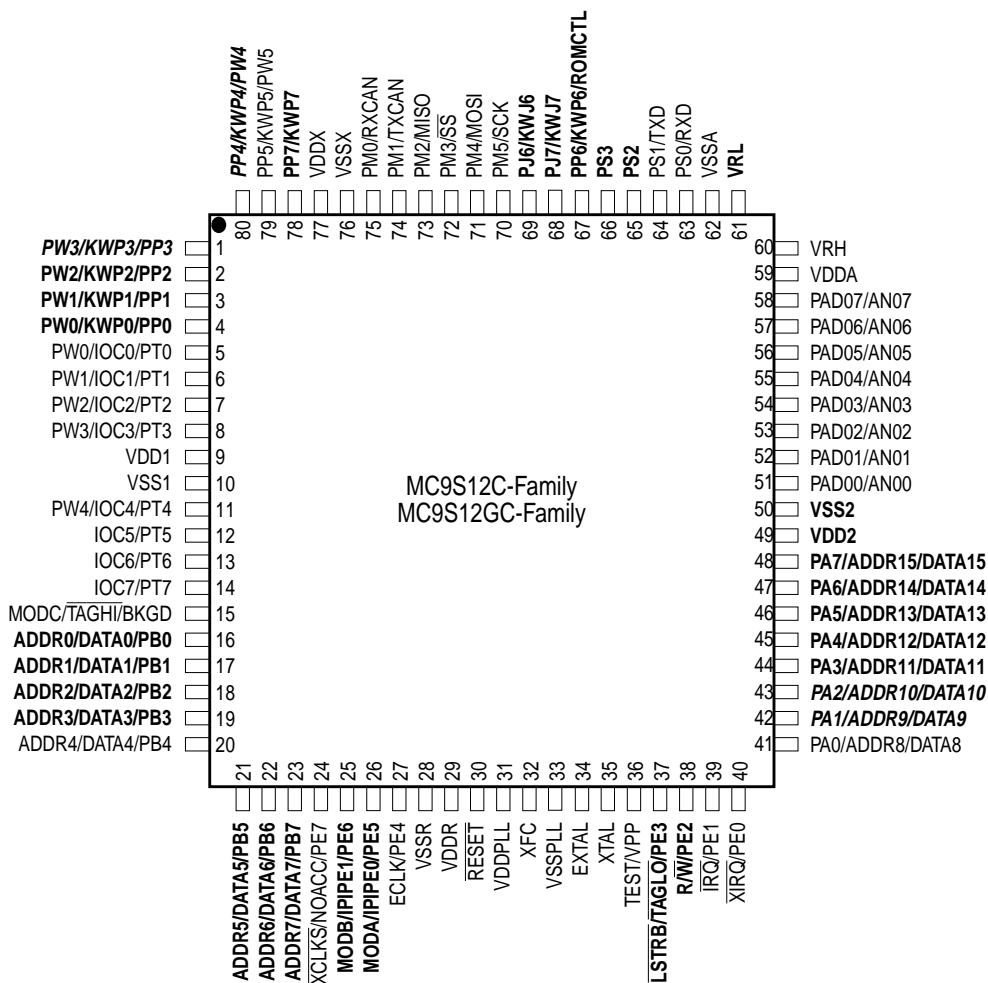

Signals shown in **Bold** are not available on the 52 or 48 Pin Package  
 Signals shown in **Bold Italic** are available in the 52, but not the 48 Pin Package

Figure 2-1 Pin Assignments in 80 QFP for MC9S12C-Family

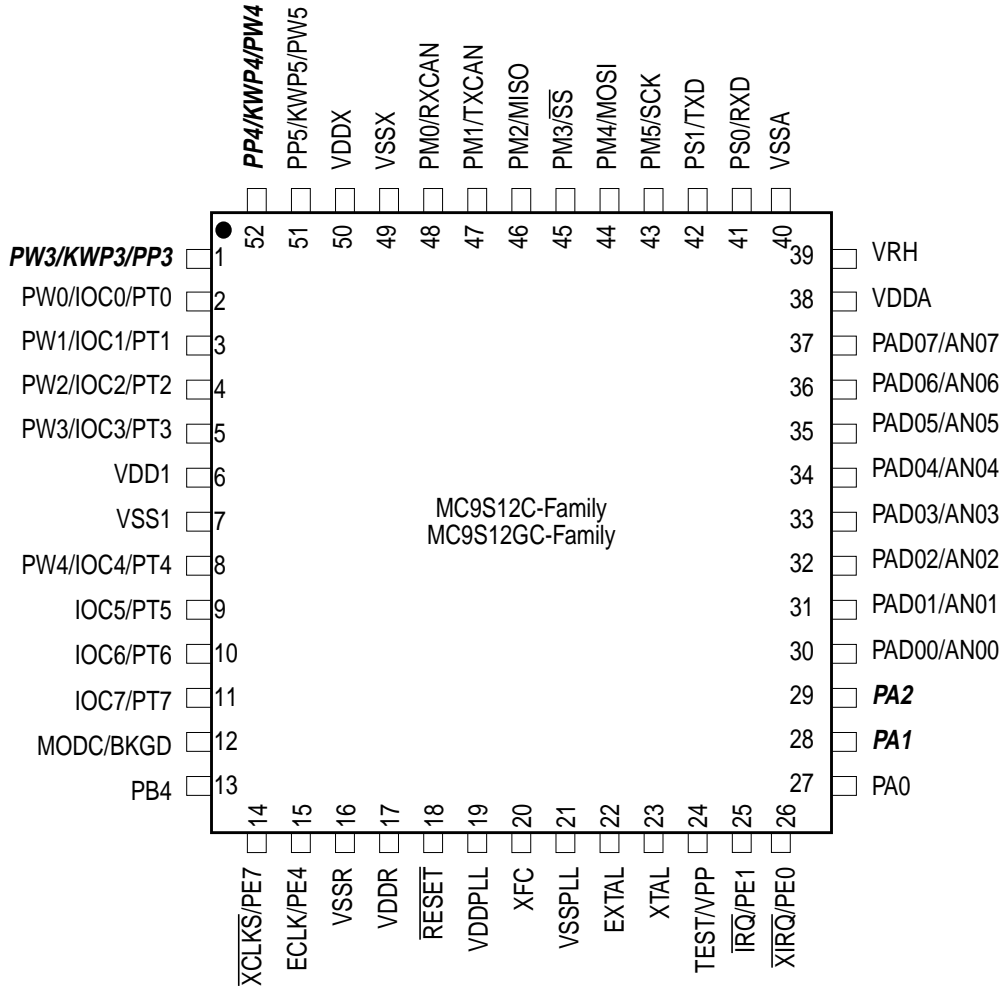

\* Signals shown in ***Bold italic*** are not available on the 48 Pin Package

**Figure 2-2 Pin assignments in 52 LQFP for MC9S12C-Family**

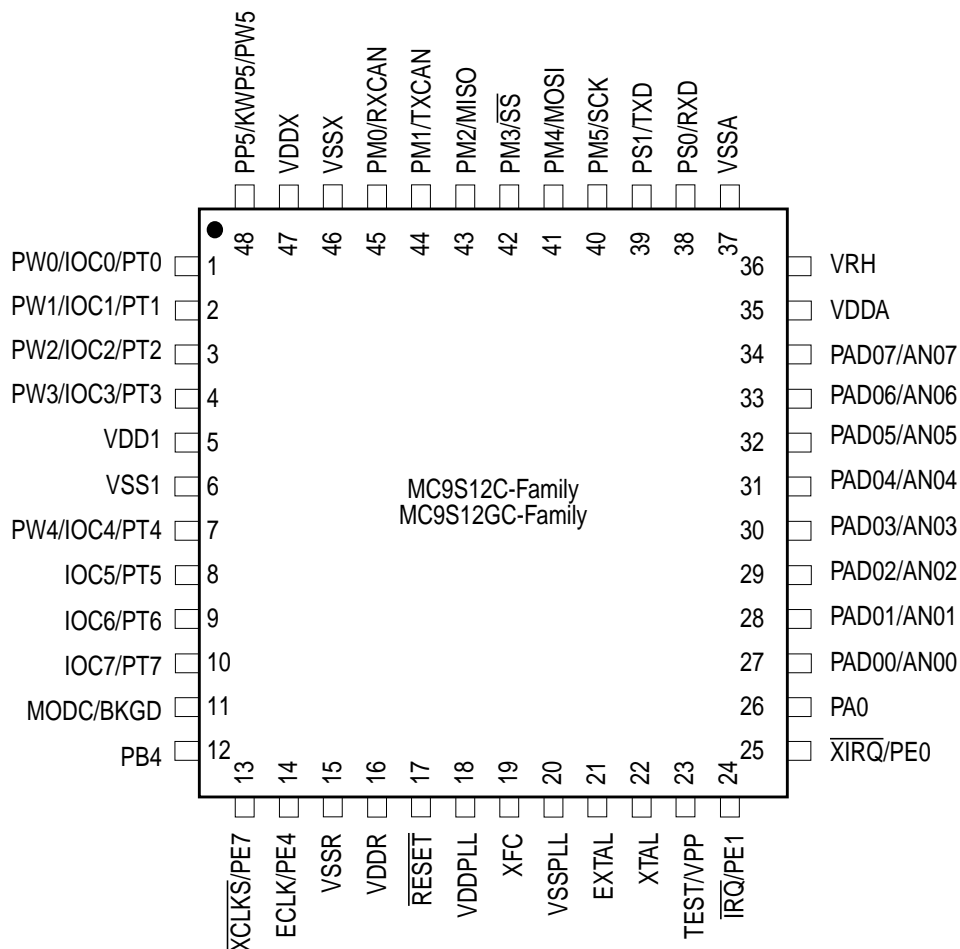

Figure 2-3 Pin Assignments in 48 LQFP for MC9S12C-Family

## 2.2 Signal Properties Summary

Table 2-1 Signal Properties

Pin Name Function 1	Pin Name Function 2	Pin Name Function 3	Power Domain	Internal Pull Resistor		Description
				CTRL	Reset State	
EXTAL	—	—	VDDPLL	NA	NA	Oscillator pins
XTAL	—	—	VDDPLL	NA	NA	
RESET	—	—	VDDX	None	None	External reset pin
XFC	—	—	VDDPLL	NA	NA	PLL loop filter pin
TEST	VPP	—	VSSX	NA	NA	Test pin only
BKGD	MODC	TAGHI	VDDX	Up	Up	Background debug, mode pin, tag signal high
PE7	NOACC	XCLKS	VDDX	PUCR	Up	Port E I/O pin, access, clock select
PE6	IPIPE1	MODB	VDDX	While RESET pin is low: Down		Port E I/O pin and pipe status
PE5	IPIPE0	MODA	VDDX	While RESET pin is low: Down		Port E I/O pin and pipe status
PE4	ECLK	—	VDDX	PUCR	Mode Dep <sup>1</sup>	Port E I/O pin, bus clock output
PE3	LSTRB	TAGLO	VDDX	PUCR	Mode Dep <sup>(1)</sup>	Port E I/O pin, low strobe, tag signal low
PE2	R/W	—	VDDX	PUCR	Mode Dep <sup>(1)</sup>	Port E I/O pin, R/W in expanded modes
PE1	IRQ	—	VDDX	PUCR	Up	Port E input, external interrupt pin
PE0	XIRQ	—	VDDX	PUCR	Up	Port E input, non-maskable interrupt pin
PA[7:3]	ADDR[15:1/ DATA[15:1]	—	VDDX	PUCR	Disabled	Port A I/O pin & multiplexed address/data
PA[2:1]	ADDR[10:9/ DATA[10:9]	—	VDDX	PUCR	Disabled	Port A I/O pin & multiplexed address/data
PA[0]	ADDR[8]/ DATA[8]	—	VDDX	PUCR	Disabled	Port A I/O pin & multiplexed address/data
PB[7:5]	ADDR[7:5]/ DATA[7:5]	—	VDDX	PUCR	Disabled	Port B I/O pin & multiplexed address/data
PB[4]	ADDR[4]/ DATA[4]	—	VDDX	PUCR	Disabled	Port B I/O pin & multiplexed address/data
PB[3:0]	ADDR[3:0]/ DATA[3:0]	—	VDDX	PUCR	Disabled	Port B I/O pin & multiplexed address/data
PAD[7:0]	AN[7:0]	—	VDDA	PERAD/P PSAD	Disabled	Port AD I/O pins and ATD inputs
PP[7]	KWP[7]	—	VDDX	PERP/ PPSP	Disabled	Port P I/O Pins and keypad wake-up
PP[6]	KWP[6]	ROMCTL	VDDX	PERP/ PPSP	Disabled	Port P I/O Pins, keypad wake-up and ROMON enable.
PP[5]	KWP[5]	PW5	VDDX	PERP/ PPSP	Disabled	Port P I/O Pin, keypad wake-up, PW5 output
PP[4:3]	KWP[4:3]	PW[4:3]	VDDX	PERP/ PPSP	Disabled	Port P I/O Pin, keypad wake-up, PWM output

Pin Name Function 1	Pin Name Function 2	Pin Name Function 3	Power Domain	Internal Pull Resistor		Description
				CTRL	Reset State	
PP[2:0]	KWP[2:0]	PW[2:0]	VDDX	PERP/ PPSP	Disabled	Port P I/O Pins, keypad wake-up, PWM outputs
PJ[7:6]	KWJ[7:6]	—	VDDX	PERJ/ PPSJ	Disabled	Port J I/O Pins and keypad wake-up
PM5	SCK	—	VDDX	PERM/ PPSM	Up	Port M I/O Pin and SPI SCK signal
PM4	MOSI	—	VDDX	PERM/ PPSM	Up	Port M I/O Pin and SPI MOSI signal
PM3	$\overline{SS}$	—	VDDX	PERM/ PPSM	Up	Port M I/O Pin and SPI $\overline{SS}$ signal
PM2	MISO	—	VDDX	PERM/ PPSM	Up	Port M I/O Pin and SPI MISO signal
PM1	TXCAN	—	VDDX	PERM/ PPSM	Up	Port M I/O Pin and CAN transmit signal <sup>2</sup>
PM0	RXCAN	—	VDDX	PERM/ PPSM	Up	Port M I/O Pin and CAN receive signal <sup>2</sup>
PS[3:2]	—	—	VDDX	PERS/ PPSS	Up	Port S I/O Pins
PS1	TXD	—	VDDX	PERS/ PPSS	Up	Port S I/O Pin and SCI transmit signal
PS0	RXD	—	VDDX	PERS/ PPSS	Up	Port S I/O Pin and SCI receive signal
PT[7:5]	IOC[7:5]	—	VDDX	PERT/ PPST	Disabled	Port T I/O Pins shared with timer (TIM)
PT[4:0]	IOC[4:0]	PW[4:0]	VDDX	PERT/ PPST	Disabled	Port T I/O Pins shared with timer and PWM

**NOTES:**

1. The PortE output buffer enable signal control at reset is determined by the PEAR register and is mode dependent. E.g. in special test mode RDWE=LSTRE=1 which enables the PE[3:2] output buffers and disables the pull-ups. Refer to S12\_MEBI user guide for PEAR register details.
2. CAN functionality is not available on the MC9S12GC-Family members

## 2.2.1 Pin Initialization for 48 & 52 Pin LQFP bond-out versions

**Not Bonded Pins** If the port pins are not bonded out in the chosen package the user should initialize the registers to be inputs with enabled pull resistance to avoid excess current consumption. This applies to the following pins:

(48LQFP): Port A[7:1], Port B[7:5], Port B[3:0], PortE[6,5,3,2], Port P[7:6], PortP[4:0], Port J[7:6], PortS[3:2]

(52LQFP): Port A[7:3], Port B[7:5], Port B[3:0], PortE[6,5,3,2], Port P[7:6], PortP[2:0], Port J[7:6], PortS[3:2]

## 2.3 Detailed Signal Descriptions

### 2.3.1 EXTAL, XTAL — Oscillator Pins

EXTAL and XTAL are the crystal driver and external clock pins. On reset all the device clocks are derived from the EXTAL input frequency. XTAL is the crystal output.

### 2.3.2 $\overline{\text{RESET}}$ — External Reset Pin

RESET is an active low bidirectional control signal that acts as an input to initialize the MCU to a known start-up state. It also acts as an open-drain output to indicate that an internal failure has been detected in either the clock monitor or COP watchdog circuit. External circuitry connected to the RESET pin should not include a large capacitance that would interfere with the ability of this signal to rise to a valid logic one within 32 ECLK cycles after the low drive is released. Upon detection of any reset, an internal circuit drives the RESET pin low and a clocked reset sequence controls when the MCU can begin normal processing.

### 2.3.3 TEST / VPP — Test Pin

This pin is reserved for test and must be tied to VSS in all applications.

### 2.3.4 XFC — PLL Loop Filter Pin

Dedicated pin used to create the PLL loop filter. See CRG BUG for more detailed information. PLL loop filter. Please ask your Motorola representative for the interactive application note to compute PLL loop filter elements. Any current leakage on this pin must be avoided.

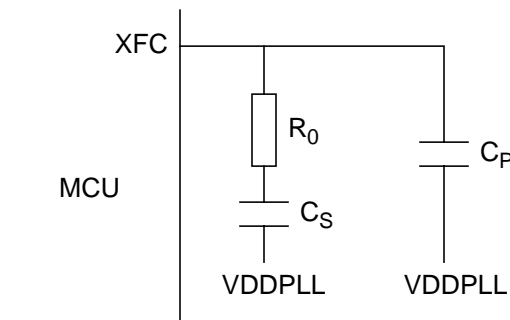

Figure 2-4 PLL Loop Filter Connections

### 2.3.5 BKGD / $\overline{\text{TAGHI}}$ / MODC — Background Debug, Tag High & Mode Pin

The BKGD /  $\overline{\text{TAGHI}}$  / MODC pin is used as a pseudo-open-drain pin for the background debug communication. In MCU expanded modes of operation when instruction tagging is on, an input low on this pin during the falling edge of E-clock tags the high half of the instruction word being read into the instruction queue. It is also used as a MCU operating mode select pin at the rising edge during reset, when the state of this pin is latched to the MODC bit.

### 2.3.6 PA[7:0] / ADDR[15:8] / DATA[15:8] — Port A I/O Pins

PA7-PA0 are general purpose input or output pins. In MCU expanded modes of operation, these pins are used for the multiplexed external address and data bus. PA[7:1] pins are not available in the 48 package version. PA[7:3] are not available in the 52 pin package version.

### 2.3.7 PB[7:0] / ADDR[7:0] / DATA[7:0] — Port B I/O Pins

PB7-PB0 are general purpose input or output pins. In MCU expanded modes of operation, these pins are used for the multiplexed external address and data bus. PB[7:5] and PB[3:0] pins are not available in the 48 nor 52 pin package version.

### 2.3.8 PE7 / NOACC / $\overline{\text{XCLKS}}$ — Port E I/O Pin 7

PE7 is a general purpose input or output pin. During MCU expanded modes of operation, the NOACC signal, when enabled, is used to indicate that the current bus cycle is an unused or “free” cycle. This signal will assert when the CPU is not using the bus. The XCLKS is an input signal which controls whether a crystal in combination with the internal Colpitts (low power) oscillator is used or whether Pierce oscillator/external clock circuitry is used. The state of this pin is latched at the rising edge of RESET. If the input is a logic low the EXTAL pin is configured for an external clock drive or a Pierce Oscillator. If input is a logic high a Colpitts oscillator circuit is configured on EXTAL and XTAL. Since this pin is an input with a pull-up device during reset, if the pin is left floating, the default configuration is a Colpitts oscillator circuit on EXTAL and XTAL.

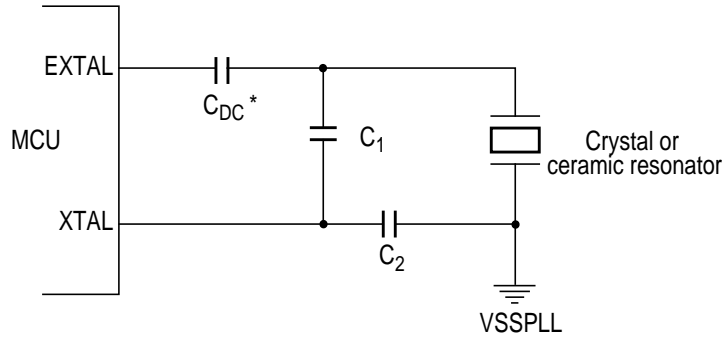

\* Due to the nature of a translated ground Colpitts oscillator a DC voltage bias is applied to the crystal  
 .Please contact the crystal manufacturer for crystal DC

**Figure 2-5 Colpitts Oscillator Connections (PE7=1)**

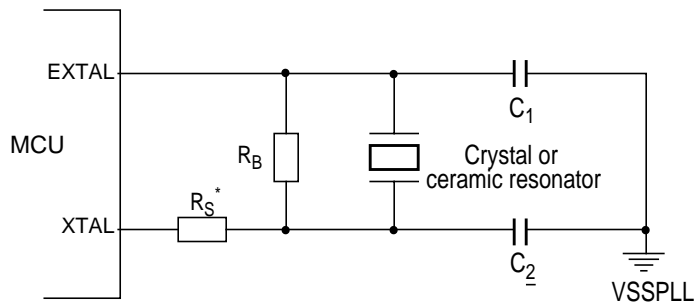

\* R<sub>s</sub> can be zero (shorted) when use with higher frequency crystals.  
 Refer to manufacturer's data.

**Figure 2-6 Pierce Oscillator Connections (PE7=0)**

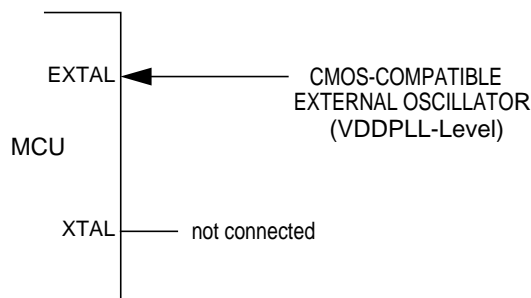

**Figure 2-7 External Clock Connections (PE7=0)**

### 2.3.9 PE6 / MODB / IPIPE1 — Port E I/O Pin 6

PE6 is a general purpose input or output pin. It is used as a MCU operating mode select pin during reset. The state of this pin is latched to the MODB bit at the rising edge of RESET. This pin is shared with the instruction queue tracking signal IPIPE1}. This pin is an input with a pull-down device which is only active when RESET is low. PE[6] is not available in the 48 / 52 pin package versions.

### 2.3.10 PE5 / MODA / IPIPE0 — Port E I/O Pin 5

PE5 is a general purpose input or output pin. It is used as a MCU operating mode select pin during reset. The state of this pin is latched to the MODA bit at the rising edge of RESET. This pin is shared with the instruction queue tracking signal IPIPE0}. This pin is an input with a pull-down device which is only active when RESET is low. This pin is not available in the 48 / 52 pin package versions.

### 2.3.11 PE4 / ECLK— Port E I/O Pin [4] / E-Clock Output

ECLK is the output connection for the internal bus clock. It is used to demultiplex the address and data in expanded modes and is used as a timing reference. ECLK frequency is equal to 1/2 the crystal frequency out of reset. The ECLK pin is initially configured as ECLK output with stretch in all expanded modes. The E clock output function depends upon the settings of the NECLK bit in the PEAR register, the IVIS bit in the MODE register and the ESTR bit in the EBICTL register. All clocks, including the E clock, are halted when the MCU is in STOP mode. It is possible to configure the MCU to interface to slow external memory. ECLK can be stretched for such accesses. Reference the MISC register (EXSTR[1:0] bits) for more information. In normal expanded narrow mode, the E clock is available for use in external select decode logic or as a constant speed clock for use in the external application system. Alternatively PE4 can be used as a general purpose input or output pin.

### 2.3.12 PE3 / $\overline{\text{LSTRB}}$ — Port E I/O Pin [3] / Low-Byte Strobe ( $\overline{\text{LSTRB}}$ )

In all modes this pin can be used as a general-purpose I/O and is an input with an active pull-up out of reset. If the strobe function is required, it should be enabled by setting the LSTRE bit in the PEAR register. This signal is used in write operations. Therefore external low byte writes will not be possible until this function is enabled. This pin is also used as  $\overline{\text{TAGLO}}$  in Special Expanded modes and is multiplexed with the  $\overline{\text{LSTRB}}$  function. This pin is not available in the 48 / 52 pin package versions.

### 2.3.13 PE2 / $\overline{\text{R/W}}$ — Port E I/O Pin [2] / Read/Write

In all modes this pin can be used as a general-purpose I/O and is an input with an active pull-up out of reset. If the read/write function is required it should be enabled by setting the RDWE bit in the PEAR register. External writes will not be possible until enabled. This pin is not available in the 48 / 52 pin package versions.

### 2.3.14 PE1 / $\overline{\text{IRQ}}$ — Port E input Pin [1] / Maskable Interrupt Pin

The  $\overline{\text{IRQ}}$  input provides a means of applying asynchronous interrupt requests to the MCU. Either falling edge-sensitive triggering or level-sensitive triggering is program selectable (INTCR register).  $\overline{\text{IRQ}}$  is always enabled and configured to level-sensitive triggering out of reset. It can be disabled by clearing IRQEN bit (INTCR register). When the MCU is reset the  $\overline{\text{IRQ}}$  function is masked in the condition code register. This pin is always an input and can always be read. There is an active pull-up on this pin while in reset and immediately out of reset. The pull-up can be turned off by clearing PUPPEE in the PUCR register.

### 2.3.15 PE0 / $\overline{\text{XIRQ}}$ — Port E input Pin [0] / Non Maskable Interrupt Pin

The  $\overline{\text{XIRQ}}$  input provides a means of requesting a non maskable interrupt after reset initialization. During reset, the X bit in the condition code register (CCR) is set and any interrupt is masked until MCU software enables it. Because the  $\overline{\text{XIRQ}}$  input is level sensitive, it can be connected to a multiple-source wired-OR network. This pin is always an input and can always be read. There is an active pull-up on this pin while in reset and immediately out of reset. The pull-up can be turned off by clearing PUPPEE in the PUCR register.

### 2.3.16 PAD[7:0] / AN[7:0] — Port AD I/O Pins [7:0]

PAD7-PAD0 are general purpose I/O pins and also analog inputs for the analog to digital converter. In order to use a PAD pin as a standard I/O, the corresponding ATDDIEN register bit must be set. These bits are cleared out of reset to configure the PAD pins for A/D operation.

When the A/D converter is active in multi-channel mode, port inputs are scanned and converted irrespective of PortAD configuration. Thus PortAD pins that are configured as digital inputs or digital outputs are also converted in the A/D conversion sequence.

### 2.3.17 PP[7] / KWP[7] — Port P I/O Pin [7]

PP7 is a general purpose input or output pin, shared with the keypad interrupt function. When configured as an input, it can generate interrupts causing the MCU to exit STOP or WAIT mode. This pin is not available in the 48 / 52 pin package versions.

### 2.3.18 PP[6] / KWP[6]/ROMCTL — Port P I/O Pin [6]

PP6 is a general purpose input or output pin, shared with the keypad interrupt function. When configured as an input, it can generate interrupts causing the MCU to exit STOP or WAIT mode. This pin is not available in the 48 / 52 pin package versions. During MCU expanded modes of operation, this pin is used to enable the Flash EEPROM memory in the memory map (ROMCTL). At the rising edge of RESET, the state of this pin is latched to the ROMON bit.

PP6=1 in emulation modes equates to ROMON =0 (ROM space externally mapped)

PP6=0 in expanded modes equates to ROMON =0 (ROM space externally mapped)

### 2.3.19 PP[5:0] / KWP[5:0] / PW[5:0] — Port P I/O Pins [5:0]

PP[5:0] are general purpose input or output pins, shared with the keypad interrupt function. When configured as inputs, they can generate interrupts causing the MCU to exit STOP or WAIT mode. PP[5:0] are also shared with the PWM output signals, PW[5:0]. Pins PP[2:0] are only available in the 80 pin package version. Pins PP[4:3] are not available in the 48 pin package version.

### 2.3.20 PJ[7:6] / KWJ[7:6] — Port J I/O Pins [7:6]

PJ[7:6] are general purpose input or output pins, shared with the keypad interrupt function. When configured as inputs, they can generate interrupts causing the MCU to exit STOP or WAIT mode. These pins are not available in the 48 pin package version nor in the 52 pin package version.

### 2.3.21 PM5 / SCK — Port M I/O Pin 5

PM5 is a general purpose input or output pin and also the serial clock pin SCK for the Serial Peripheral Interface (SPI).

### 2.3.22 PM4 / MOSI — Port M I/O Pin 4

PM4 is a general purpose input or output pin and also the master output (during master mode) or slave input (during slave mode) pin for the Serial Peripheral Interface (SPI).

### 2.3.23 PM3 / $\overline{SS}$ — Port M I/O Pin 3

PM3 is a general purpose input or output pin and also the slave select pin  $\overline{SS}$  for the Serial Peripheral Interface (SPI).

### 2.3.24 PM2 / MISO — Port M I/O Pin 2

PM2 is a general purpose input or output pin and also the master input (during master mode) or slave output (during slave mode) pin for the Serial Peripheral Interface (SPI).

### 2.3.25 PM1 / TXCAN — Port M I/O Pin 1

PM1 is a general purpose input or output pin and the transmit pin, TXCAN, of the CAN module if available.

### 2.3.26 PM0 / RXCAN — Port M I/O Pin 0

PM0 is a general purpose input or output pin and the receive pin, RXCAN, of the CAN module if available.

### 2.3.27 PS[3:2] — Port S I/O Pins [3:2]

PS3 and PS2 are general purpose input or output pins. These pins are not available in the 48 / 52 pin package versions.

### 2.3.28 PS1 / TXD — Port S I/O Pin 1

PS1 is a general purpose input or output pin and the transmit pin, TXD, of Serial Communication Interface (SCI).

### 2.3.29 PS0 / RXD — Port S I/O Pin 0

PS0 is a general purpose input or output pin and the receive pin, RXD, of Serial Communication Interface (SCI).

### 2.3.30 PPT[7:5] / IOC[7:5] — Port T I/O Pins [7:5]

PT7-PT5 are general purpose input or output pins. They can also be configured as the timer system input capture or output compare pins IOC7-IOC5.

### 2.3.31 PT[4:0] / IOC[4:0] / PW[4:0]— Port T I/O Pins [4:0]

PT4-PT0 are general purpose input or output pins. They can also be configured as the timer system input capture or output compare pins IOC4-IOC0 or as the PWM outputs PW[4:0].

## 2.4 Power Supply Pins

### 2.4.1 VDDX, VSSX — Power & Ground Pins for I/O Drivers

External power and ground for I/O drivers. Bypass requirements depend on how heavily the MCU pins are loaded.

### 2.4.2 VDDR, VSSR — Power & Ground Pins for I/O Drivers & for Internal Voltage Regulator

External power and ground for the internal voltage regulator. Connecting VDDR to ground disables the internal voltage regulator.

### 2.4.3 VDD1, VDD2, VSS1, VSS2 — Internal Logic Power Pins

Power is supplied to the MCU through VDD and VSS. This 2.5V supply is derived from the internal voltage regulator. There is no static load on those pins allowed. The internal voltage regulator is turned off, if VDDR is tied to ground.

## 2.4.4 VDDA, VSSA — Power Supply Pins for ATD and VREG

VDDA, VSSA are the power supply and ground input pins for the voltage regulator reference and the analog to digital converter.

## 2.4.5 VRH, VRL — ATD Reference Voltage Input Pins

VRH and VRL are the reference voltage input pins for the analog to digital converter.

## 2.4.6 VDDPLL, VSSPLL — Power Supply Pins for PLL

Provides operating voltage and ground for the Oscillator and the Phased-Locked Loop. This allows the supply voltage to the Oscillator and PLL to be bypassed independently. This 2.5V voltage is generated by the internal voltage regulator.

**Table 2-2 MC9S12C-Family Power and Ground Connection Summary**

Mnemonic	Nominal Voltage	Description
VDD1 VDD2	2.5 V	Internal power and ground generated by internal regulator. These also allow an external source to supply the core VDD/VSS voltages and bypass the internal voltage regulator. In the 48 and 52 LQFP packages VDD2 and VSS2 are not available.
VSS1 VSS2	0V	
VDDR	5.0 V	External power and ground, supply to internal voltage regulator.
VSSR	0 V	
VDDX	5.0 V	External power and ground, supply to pin drivers.
VSSX	0 V	
VDDA	5.0 V	Operating voltage and ground for the analog-to-digital converters and the reference for the internal voltage regulator, allows the supply voltage to the A/D to be bypassed independently.
VSSA	0 V	
VRH	5.0 V	Reference voltage low for the ATD converter. In the 48 and 52 LQFP packages VRL is bonded to VSSA.
VRL	0 V	
VDDPLL	2.5 V	Provides operating voltage and ground for the Phased-Locked Loop. This allows the supply voltage to the PLL to be bypassed independently. Internal power and ground generated by internal regulator.
VSSPLL	0 V	

**NOTE:** All VSS pins must be connected together in the application. Because fast signal transitions place high, short-duration current demands on the power supply, use bypass capacitors with high-frequency characteristics and place them as close to the MCU as possible. Bypass requirements depend on MCU pin load.

## Section 3 System Clock Description

The Clock and Reset Generator provides the internal clock signals for the core and all peripheral modules. **Figure 3-1** shows the clock connections from the CRG to all modules. Consult the CRG Block User Guide for details on clock generation.

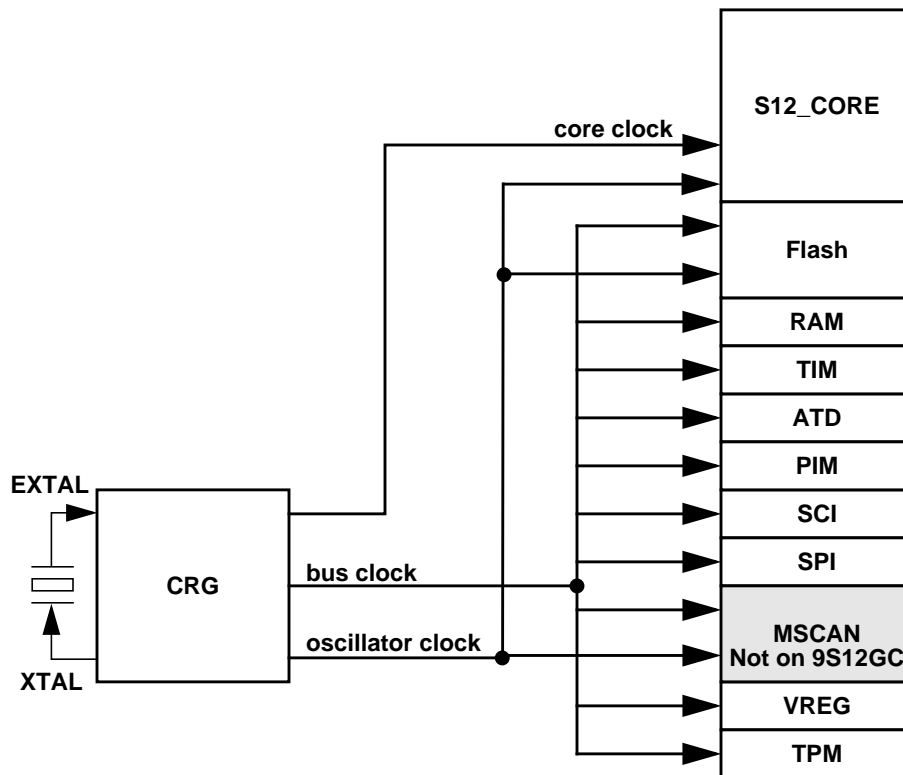

Figure 3-1 Clock Connections

## Section 4 Modes of Operation

### 4.1 Overview

Eight possible modes determine the operating configuration of the MC9S12C Family. Each mode has an associated default memory map and external bus configuration controlled by a further pin.

Three low power modes exist for the device.

### 4.2 Chip Configuration Summary

The operating mode out of reset is determined by the states of the MODC, MODB, and MODA pins during reset. The MODC, MODB, and MODA bits in the MODE register show the current operating mode and provide limited mode switching during operation. The states of the MODC, MODB, and MODA pins are

latched into these bits on the rising edge of the reset signal. The ROMCTL signal allows the setting of the ROMON bit in the MISC register thus controlling whether the internal Flash is visible in the memory map. ROMON = 1 mean the Flash is visible in the memory map. The state of the ROMCTL pin is latched into the ROMON bit in the MISC register on the rising edge of the reset signal.

**Table 4-1 Mode Selection**

BKGD = MODC	PE6 = MODB	PE5 = MODA	PP6 = ROMCTL	ROMON Bit	Mode Description
0	0	0	X	1	Special Single Chip, BDM allowed and ACTIVE. BDM is allowed in all other modes but a serial command is required to make BDM active.
0	0	1	0	1	Emulation Expanded Narrow, BDM allowed
			1	0	
0	1	0	X	0	Special Test (Expanded Wide), BDM allowed
0	1	1	0	1	Emulation Expanded Wide, BDM allowed
			1	0	
1	0	0	X	1	Normal Single Chip, BDM allowed
1	0	1	0	0	Normal Expanded Narrow, BDM allowed
			1	1	
1	1	0	X	1	Peripheral; BDM allowed but bus operations would cause bus conflicts (must not be used)
1	1	1	0	0	Normal Expanded Wide, BDM allowed
			1	1	

For further explanation on the modes refer to the S12\_MEBI block guide.

**Table 4-2 Clock Selection Based on PE7**

PE7 = XCLKS	Description
1	Colpitts Oscillator selected
0	Pierce Oscillator/external clock selected

### 4.3 Security

The device will make available a security feature preventing the unauthorized read and write of the memory contents. This feature allows:

- Protection of the contents of FLASH,
- Operation in single-chip mode,
- Operation from external memory with internal FLASH disabled.

The user must be reminded that part of the security must lie with the user’s code. An extreme example would be user’s code that dumps the contents of the internal program. This code would defeat the purpose of security. At the same time the user may also wish to put a back door in the user’s program. An example

of this is the user downloads a key through the SCI which allows access to a programming routine that updates parameters.

### 4.3.1 Securing the Microcontroller

Once the user has programmed the FLASH, the part can be secured by programming the security bits located in the FLASH module. These non-volatile bits will keep the part secured through resetting the part and through powering down the part.

The security byte resides in a portion of the Flash array.

Check the Flash Block User Guide for more details on the security configuration.

### 4.3.2 Operation of the Secured Microcontroller

#### 4.3.2.1 Normal Single Chip Mode

This will be the most common usage of the secured part. Everything will appear the same as if the part was not secured with the exception of BDM operation. The BDM operation will be blocked.

#### 4.3.2.2 Executing from External Memory

The user may wish to execute from external space with a secured microcontroller. This is accomplished by resetting directly into expanded mode. The internal FLASH will be disabled. BDM operations will be blocked.

### 4.3.3 Unsecuring the Microcontroller

In order to unsecure the microcontroller, the internal FLASH must be erased. This can be done through an external program in expanded mode or via a sequence of BDM commands. Unsecuring is also possible via the Backdoor Key Access. Refer to Flash Block Guide for details.

Once the user has erased the FLASH, the part can be reset into special single chip mode. This invokes a program that verifies the erasure of the internal FLASH. Once this program completes, the user can erase and program the FLASH security bits to the unsecured state. This is generally done through the BDM, but the user could also change to expanded mode (by writing the mode bits through the BDM) and jumping to an external program (again through BDM commands). Note that if the part goes through a reset before the security bits are reprogrammed to the unsecure state, the part will be secured again.

## 4.4 Low Power Modes

The microcontroller features three main low power modes. Consult the respective Block User Guide for information on the module behavior in Stop, Pseudo Stop, and Wait Mode. An important source of information about the clock system is the Clock and Reset Generator User Guide (CRG).

### 4.4.1 Stop

Executing the CPU STOP instruction stops all clocks and the oscillator thus putting the chip in fully static mode. Wake up from this mode can be done via reset or external interrupts.

### 4.4.2 Pseudo Stop

This mode is entered by executing the CPU STOP instruction. In this mode the oscillator is still running and the Real Time Interrupt (RTI) or Watchdog (COP) sub module can stay active. Other peripherals are turned off. This mode consumes more current than the full STOP mode, but the wake up time from this mode is significantly shorter.

### 4.4.3 Wait

This mode is entered by executing the CPU WAI instruction. In this mode the CPU will not execute instructions. The internal CPU signals (address and databus) will be fully static. All peripherals stay active. For further power consumption reduction the peripherals can individually turn off their local clocks.

### 4.4.4 Run

Although this is not a low power mode, unused peripheral modules should not be enabled in order to save power.

## Section 5 Resets and Interrupts

### 5.1 Overview

Consult the Exception Processing section of the CPU12 Reference Manual for information.

### 5.2 Vectors

#### 5.2.1 Vector Table

Table 5-1 lists interrupt sources and vectors in default order of priority.

**Table 5-1 Interrupt Vector Locations**

Vector Address	Interrupt Source	CCR Mask	Local Enable	HPRIO Value to Elevate
\$FFFE, \$FFFF	External Reset, Power On Reset or Low Voltage Reset (see CRG Flags Register to determine reset source)	None	None	–
\$FFFC, \$FFFD	Clock Monitor fail reset	None	COPCTL (CME, FCME)	–
\$FFFA, \$FFFB	COP failure reset	None	COP rate select	–
\$FFF8, \$FFF9	Unimplemented instruction trap	None	None	–

\$FFF6, \$FFF7	SWI	None	None	–
\$FFF4, \$FFF5	XIRQ	X-Bit	None	–
\$FFF2, \$FFF3	IRQ	I-Bit	INTCR (IRQEN)	\$F2
\$FFF0, \$FFF1	Real Time Interrupt	I-Bit	CRGINT (RTIE)	\$F0
\$FFEE, \$FFEF	Standard Timer channel 0	I-Bit	TIE (C0I)	\$EE
\$FFEC, \$FFED	Standard Timer channel 1	I-Bit	TIE (C1I)	\$EC
\$FFEA, \$FFEB	Standard Timer channel 2	I-Bit	TIE (C2I)	\$EA
\$FFE8, \$FFE9	Standard Timer channel 3	I-Bit	TIE (C3I)	\$E8
\$FFE6, \$FFE7	Standard Timer channel 4	I-Bit	TIE (C4I)	\$E6
\$FFE4, \$FFE5	Standard Timer channel 5	I-Bit	TIE (C5I)	\$E4
\$FFE2, \$FFE3	Standard Timer channel 6	I-Bit	TIE (C6I)	\$E2
\$FFE0, \$FFE1	Standard Timer channel 7	I-Bit	TIE (C7I)	\$E0
\$FFDE, \$FFDF	Standard Timer overflow	I-Bit	TMSK2 (TOI)	\$DE
\$FFDC, \$FFDD	Pulse accumulator A overflow	I-Bit	PACTL (PAOVI)	\$DC
\$FFDA, \$FFDB	Pulse accumulator input edge	I-Bit	PACTL (PAI)	\$DA
\$FFD8, \$FFD9	SPI	I-Bit	SPICR1 (SPIE, SPTIE)	\$D8
\$FFD6, \$FFD7	SCI	I-Bit	SCICR2 (TIE, TCIE, RIE, ILIE)	\$D6
\$FFD4, \$FFD5	Reserved			
\$FFD2, \$FFD3	ATD	I-Bit	ATDCTL2 (ASCIE)	\$D2
\$FFD0, \$FFD1	Reserved			
\$FFCE, \$FFCF	Port J	I-Bit	PIEP (PIEP7-6)	\$CE
\$FFCC, \$FFCD	Reserved			
\$FFCA, \$FFCB	Reserved			
\$FFC8, \$FFC9	Reserved			
\$FFC6, \$FFC7	CRG PLL lock	I-Bit	PLLCR (LOCKIE)	\$C6
\$FFC4, \$FFC5	CRG Self Clock Mode	I-Bit	PLLCR (SCMIE)	\$C4
\$FFBA to \$FFC3	Reserved			
\$FFB8, \$FFB9	FLASH	I-Bit	FCNFG (CCIE, CBEIE)	\$B8
\$FFB6, \$FFB7	CAN wake-up <sup>1</sup>	I-Bit	CANRIER (WUPIE)	\$B6
\$FFB4, \$FFB5	CAN errors <sup>1</sup>	I-Bit	CANRIER (CSCIE, OVRIE)	\$B4
\$FFB2, \$FFB3	CAN receive <sup>1</sup>	I-Bit	CANRIER (RXFIE)	\$B2
\$FFB0, \$FFB1	CAN transmit <sup>1</sup>	I-Bit	CANTIER (TXEIE[2:0])	\$B0
\$FF90 to \$FFAF	Reserved			
\$FF8E, \$FF8F	Port P	I-Bit	PIEP (PIEP7-0)	\$8E
\$FF8C, \$FF8D	PWM Emergency Shutdown	I-Bit	PWMSDN(PWMIE)	\$8C
\$FF8A, \$FF8B	VREG LVI	I-Bit	CTRL0 (LVIE)	\$8A
\$FF80 to \$FF89	Reserved			

## NOTES:

1. Not available on MC9S12GC-Family members

## 5.3 Resets

Resets are a subset of the interrupts featured in **Table 5-1**. The different sources capable of generating a system reset are summarized in **Table 5-2**. When a reset occurs, MCU registers and control bits are

changed to known start-up states. Refer to the respective module Block User Guides for register reset states.

### 5.3.1 Reset Summary Table

**Table 5-2 Reset Summary**

Reset	Priority	Source	Vector
Power-on Reset	1	CRG Module	\$FFFE, \$FFFF
External Reset	1	RESET pin	\$FFFE, \$FFFF
Low Voltage Reset	1	VREG Module	\$FFFE, \$FFFF
Clock Monitor Reset	2	CRG Module	\$FFFC, \$FFFD
COP Watchdog Reset	3	CRG Module	\$FFFA, \$FFFB

### 5.3.2 Effects of Reset

When a reset occurs, MCU registers and control bits are changed to known start-up states. Refer to the respective module Block User Guides for register reset states. Refer to the HCS12 Multiplexed External Bus Interface (MEBI) Block Guide for mode dependent pin configuration of port A, B and E out of reset.

Refer to the PIM Block User Guide for reset configurations of all peripheral module ports.

Refer to **Figure 1-2** to **Figure 1-5** footnotes for locations of the memories depending on the operating mode after reset.

The RAM array is not automatically initialized out of reset.

**NOTE:** For devices assembled in 48-pin or 52-pin LQFP packages all non-bonded out pins should be configured as outputs after reset in order to avoid current drawn from floating inputs. Refer to **Table 2-1** for affected pins.

## Section 6 HCS12 Core Block Description

Consult the individual block guides for information about the HCS12 core modules, i.e. central processing unit (CPU), interrupt module (INT), module mapping control module (MMC), multiplexed external bus interface (MEBI), debug12 module (DBG12) and background debug mode module (BDM).

Where the CPU12 Reference Manual refers to cycles this is equivalent to device bus clock periods.

### 6.1 Device-specific information

#### 6.1.1 PPAGE

External paging is not supported on these devices. In order to access the 16K flash blocks in the address range \$8000-\$BFFF the PPAGE register must be loaded with the corresponding value for this range. Refer to **Table 6-1** for device specific page mapping.

For all devices Flash Page 3F is visible in the \$C000-\$FFFF range if ROMON is set. For all devices (except 9S12GC16) Page 3E is also visible in the \$4000-\$7FFF range if ROMHM is cleared and ROMON is set. For all devices apart from MC9S12C32 Flash Page 3D is visible in the \$0000-\$3FFF range if ROMON is set...

**Table 6-1 Device Specific Flash PAGE Mapping**

Device	PAGE	PAGE visible with PPAGE contents
MC9S12GC16	3F	\$00,\$01,\$02,\$03,\$04,\$05,\$06,\$07,\$08,\$09.....\$36DS,\$37,\$38,\$39,\$3A,\$3B,\$3C,\$3D,\$3E,\$3F
MC9S12C32	3E	\$00,\$02,\$04,\$06,\$08,\$0A,\$0C,\$0E,\$10,\$12.....\$2C,\$2E,\$30,\$32,\$34,\$36,\$38,\$3A,\$3C,\$3E
MC9S12GC32	3F	\$01,\$03,\$05,\$07,\$09,\$0B,\$0D,\$0F,\$11,\$13.....\$2D,\$2F,\$31,\$33,\$35,\$37,\$39,\$3B,\$3D,\$3F
MC9S12C64 MC9S12GC64	3C	\$00,\$04,\$08,\$0C,\$10,\$14,\$18,\$1C,\$20,\$24,\$28,\$2C,\$30,\$34,\$38,\$3C
	3D	\$01,\$05,\$09,\$0D,\$11,\$15,\$19,\$1D,\$21,\$25,\$29,\$2D,\$31,\$35,\$39,\$3D
	3E	\$02,\$06,\$0A,\$0E,\$12,\$16,\$1A,\$1E,\$22,\$26,\$2A,\$2E,\$32,\$36,\$3A,\$3E
	3F	\$03,\$07,\$0B,\$0F,\$13,\$17,\$1B,\$1F,\$23,\$27,\$2B,\$2F,\$33,\$37,\$3B,\$3F
MC9S12C96	3A	\$00,\$02,\$08,\$0A,\$10,\$12,\$18,\$1A,\$20,\$22,\$28,\$2A,\$30,\$32,\$38,\$3A
	3B	\$01,\$03,\$09,\$0B,\$11,\$13,\$19,\$1B,\$21,\$23,\$29,\$2B,\$31,\$33,\$39,\$3B
	3C	\$04,\$0C,\$14,\$1C,\$24,\$2C,\$34,\$3C
	3D	\$05,\$0D,\$15,\$1D,\$25,\$2D,\$35,\$3D
	3E	\$06,\$0E,\$16,\$1E,\$26,\$2E,\$36,\$3E
	3F	\$07,\$0F,\$17,\$1F,\$27,\$2F,\$37,\$3F
MC9S12C128 MC9S12GC128	38	\$00,\$08,\$10,\$18,\$20,\$28,\$30,\$38
	39	\$01,\$09,\$11,\$19,\$21,\$29,\$31,\$39
	3A	\$02,\$0A,\$12,\$1A,\$22,\$2A,\$32,\$3A
	3B	\$03,\$0B,\$13,\$1B,\$23,\$2B,\$33,\$3B
	3C	\$04,\$0C,\$14,\$1C,\$24,\$2C,\$34,\$3C
	3D	\$05,\$0D,\$15,\$1D,\$25,\$2D,\$35,\$3D
	3E	\$06,\$0E,\$16,\$1E,\$26,\$2E,\$36,\$3E
	3F	\$07,\$0F,\$17,\$1F,\$27,\$2F,\$37,\$3F

### 6.1.2 BDM alternate clock

The BDM section of S12 Core User Guide reference to alternate clock is equivalent to oscillator clock.

### 6.1.3 Extended Address Range Emulation Implications

In order to emulate the MC9S12GC or MC9S12C-Family devices, external addressing of a 128K memory map is required. This is provided in a 112 LQFP package version which includes the 3 necessary extra external address bus signals via PortK[2:0]. This package version is for emulation only and not provided as a general production package.

The reset state of DDRK is \$00, configuring the pins as inputs.

The reset state of PUPKE in the PUCR register is “1” enabling the internal PortK pullups.

In this reset state the pull-ups provide a defined state and prevent a floating input, thereby preventing unnecessary current flow at the input stage.

To prevent unnecessary current flow in production package options, the states of DDRK and PUPKE should not be changed by software.

## Section 7 Voltage Regulator (VREG) Block Description

Consult the VREG Block User Guide for information about the dual output linear voltage regulator.

### 7.1 Device-specific information

The VREG is part of the IPBus domain.

#### 7.1.1 VREGEN

VREGEN is connected internally to VDDR.

#### 7.1.2 VDD1, VDD2, VSS1, VSS2

In the 80 pin QFP package versions, both internal VDD and VSS of the 2.5V domain are bonded out on 2 sides of the device as two pin pairs (VDD1, VSS1 & VDD2, VSS2). VDD1 and VDD2 are connected together internally. VSS1 and VSS2 are connected together internally.

The extra pin pair enables systems using the 80 pin package to employ better supply routing and further decoupling.

## Section 8 Recommended Printed Circuit Board Layout

The PCB must be carefully laid out to ensure proper operation of the voltage regulator as well as of the MCU itself. The following rules must be observed:

- Every supply pair must be decoupled by a ceramic capacitor connected as near as possible to the corresponding pins (C1 - C6).
- Central point of the ground star should be the VSSR pin.
- Use low ohmic low inductance connections between VSS1, VSS2 and VSSR.
- VSSPLL must be directly connected to VSSR.
- Keep traces of VSSPLL, EXTAL and XTAL as short as possible and occupied board area for C7, C8, C11 and Q1 as small as possible.
- Do not place other signals or supplies underneath area occupied by C7, C8, C10 and Q1 and the connection area to the MCU.
- Central power input should be fed in at the VDDA/VSSA pins.

**Table 8-1 Recommended External Component Values**

Component	Purpose	Type	Value
C1	VDD1 filter capacitor	ceramic X7R	220nF, 470nF <sup>1</sup>
C2	VDD2 filter capacitor (80 QFP only)	ceramic X7R	220nF
C3	VDDA filter capacitor	ceramic X7R	100nF
C4	VDDR filter capacitor	X7R/tantalum	>=100nF
C5	VDDPLL filter capacitor	ceramic X7R	100nF
C6	VDDX filter capacitor	X7R/tantalum	>=100nF
C7	OSC load capacitor	See PLL specification chapter	
C8	OSC load capacitor		
C9	PLL loop filter capacitor	See PLL specification chapter	
C10	PLL loop filter capacitor		
C11	DC cutoff capacitor	Colpitts mode only, if recommended by quartz manufacturer	
R1	PLL loop filter resistor	See PLL Specification chapter	
R2 / R <sub>B</sub>	PLL loop filter resistor	Pierce mode only	
R3 / R <sub>S</sub>	PLL loop filter resistor		
Q1	Quartz		

## NOTES:

1. In 48LQFP and 52LQFP package versions, VDD2 is not available. Thus 470nF must be connected to VDD1.

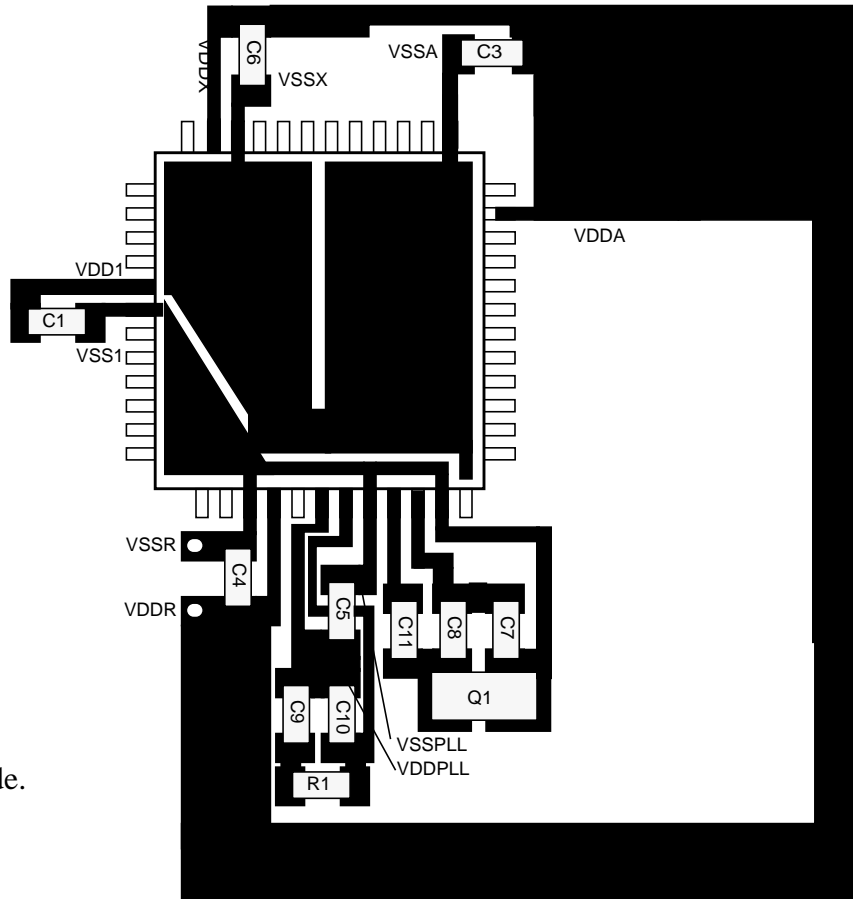

Note:  
Oscillator in  
Colpitts mode.

Figure 8-1 Recommended PCB Layout (48 LQFP)

)

NOTE: Oscillator in Colpitts mode.

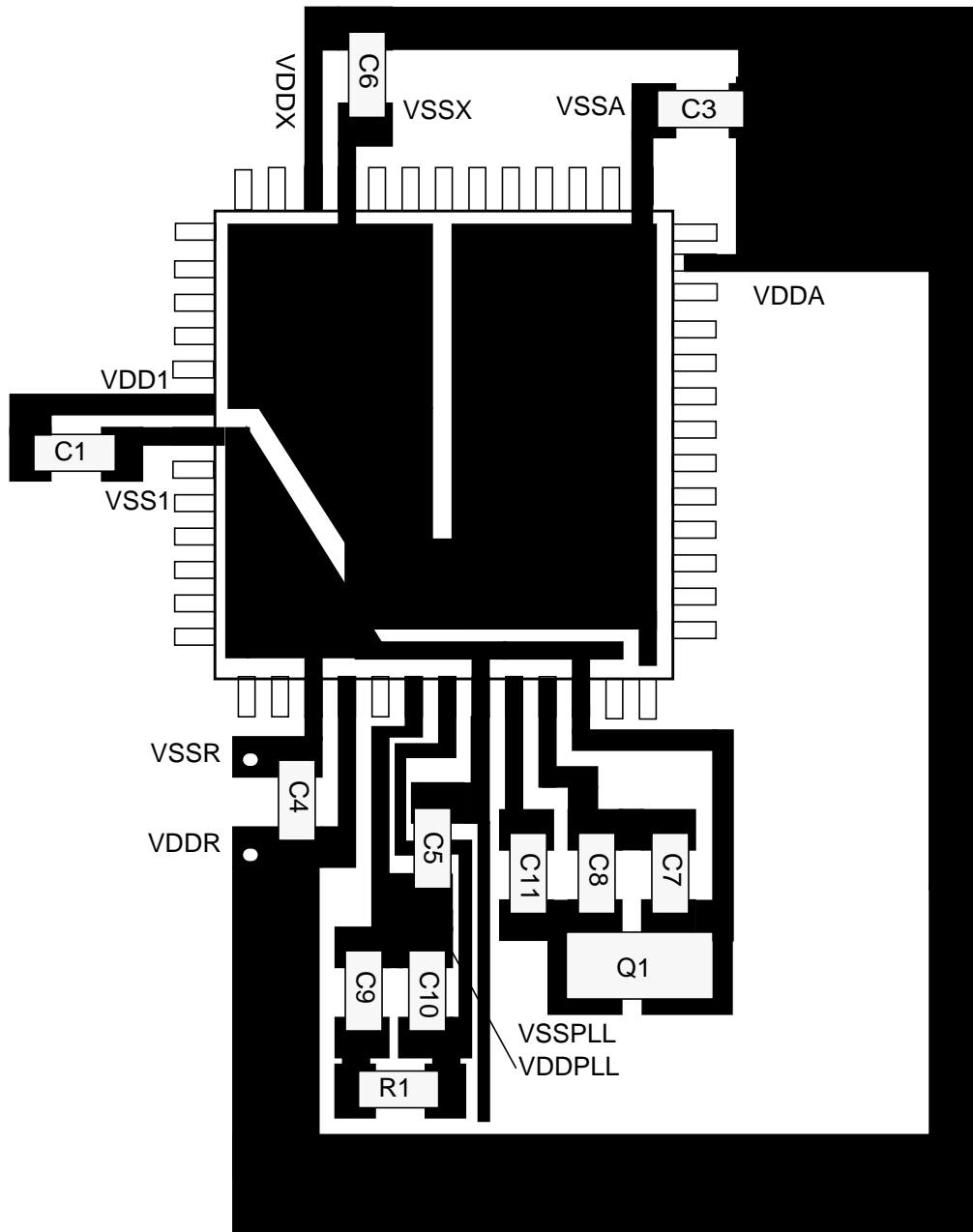

Figure 8-2 Recommended PCB Layout (52 LQFP)

)  
 NOTE: Oscillator in Colpitts mode.

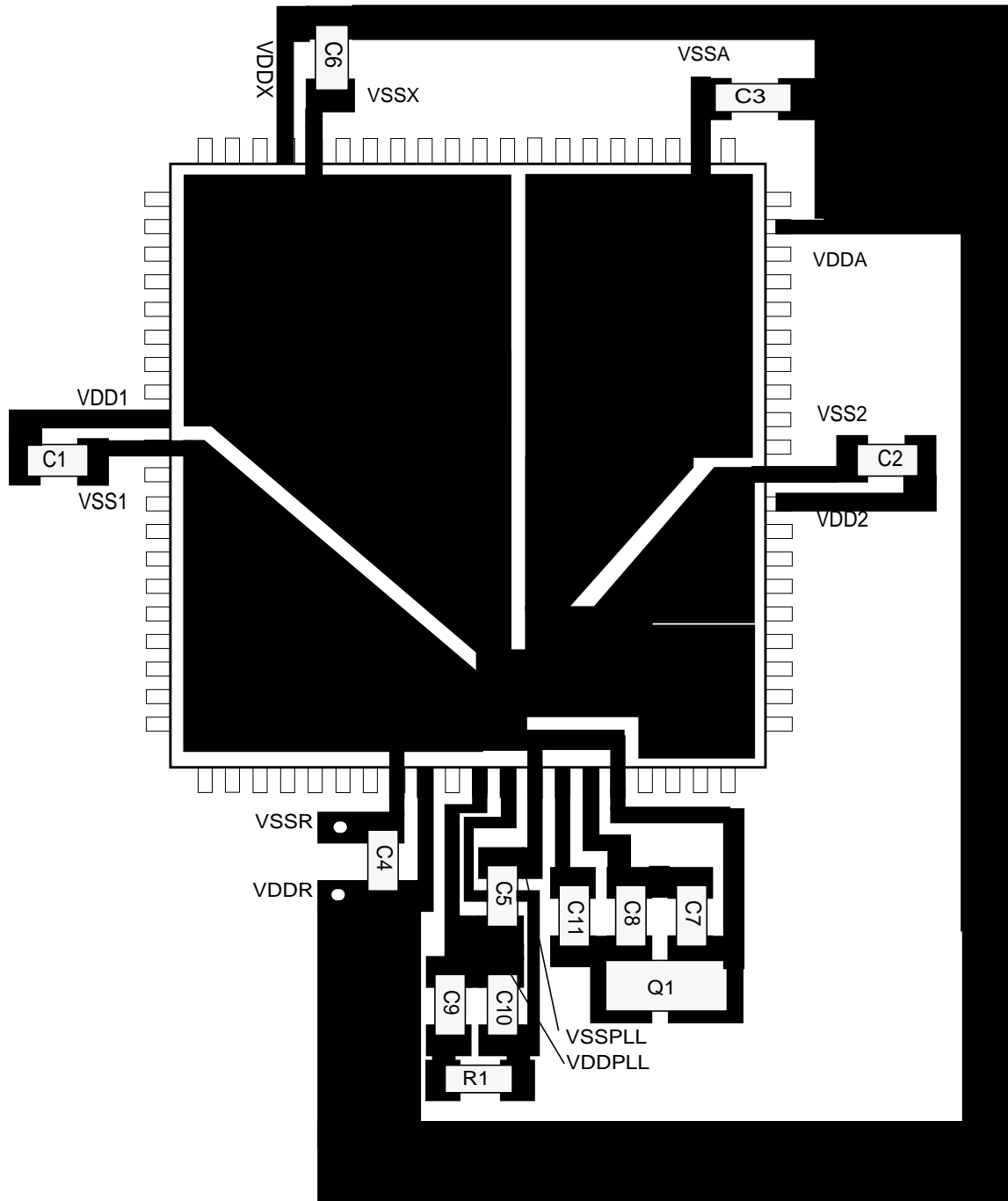

Figure 8-3 Recommended PCB Layout (80 QFP)

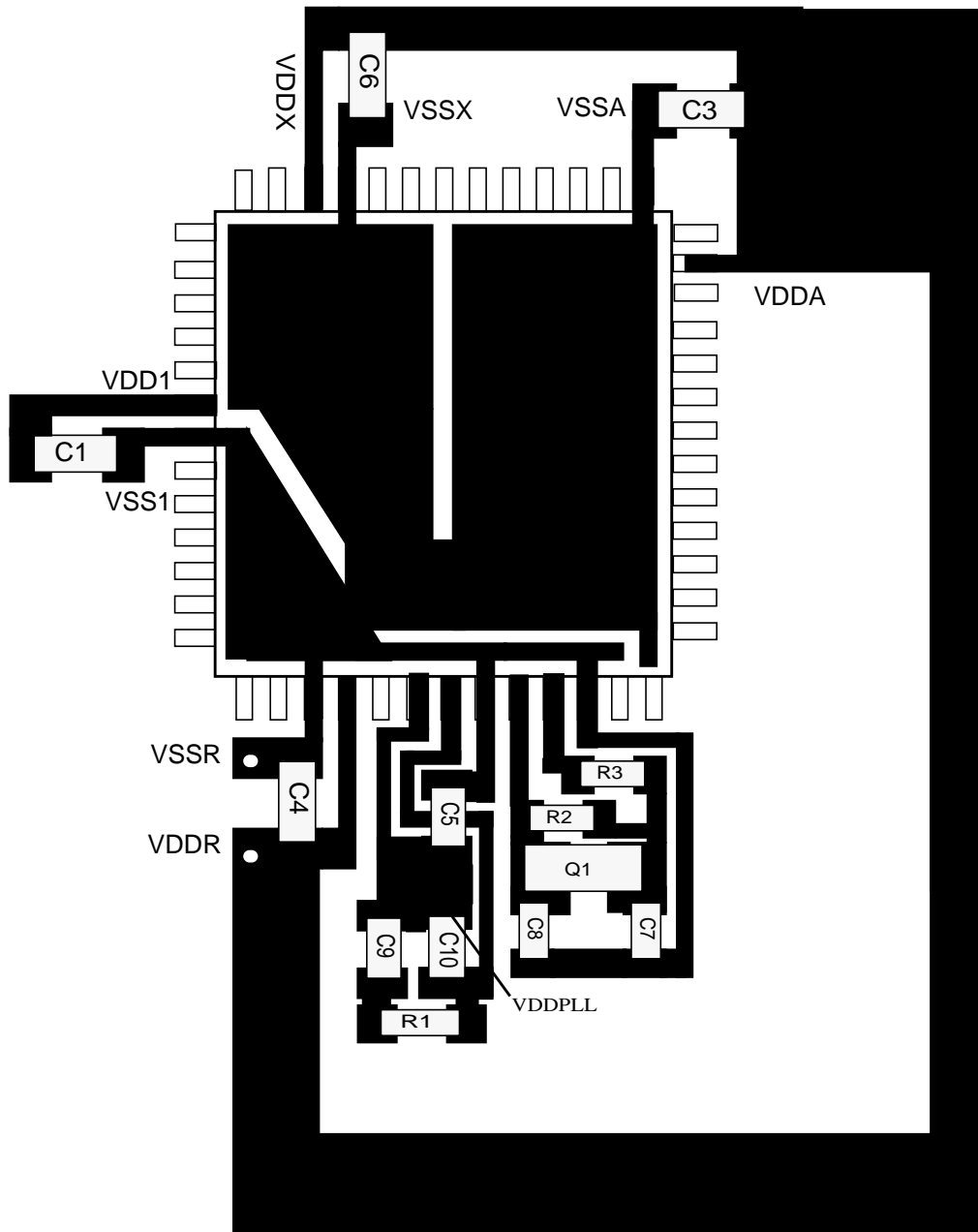

Figure 8-4 Recommended PCB Layout for 48 LQFP Pierce Oscillator

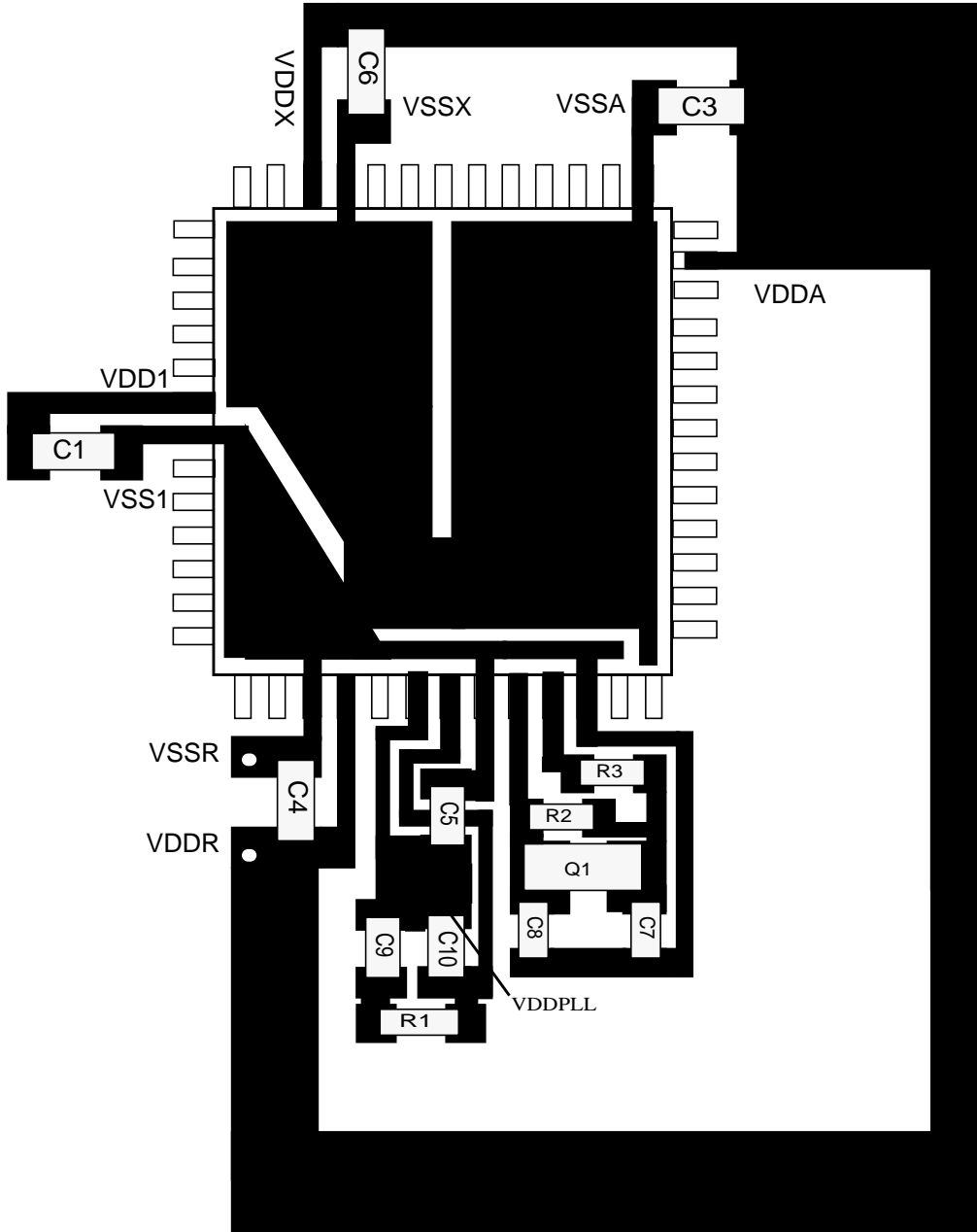

Figure 8-5 Recommended PCB Layout for 52 LQFP Pierce Oscillator

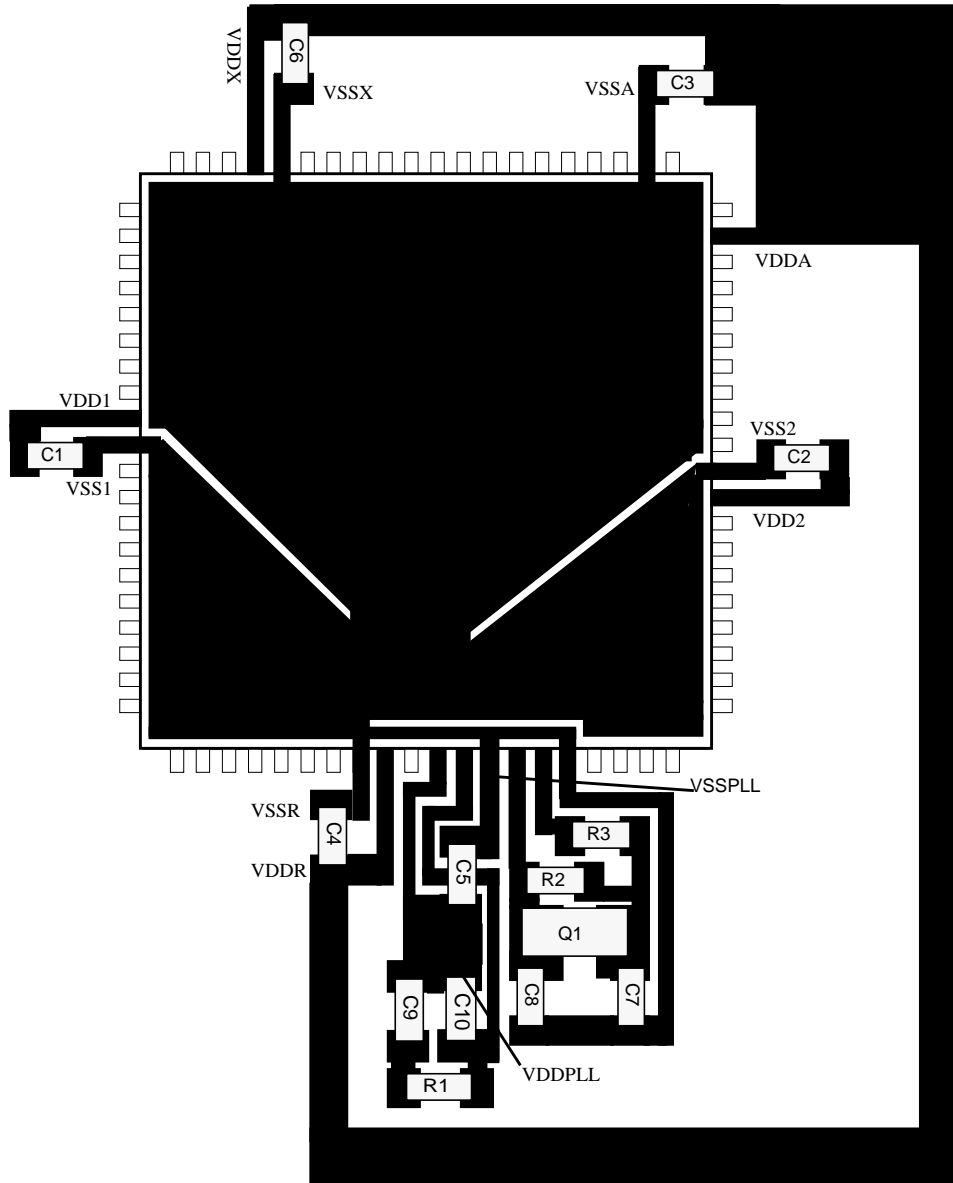

Figure 8-6 Recommended PCB Layout for 80QFP Pierce Oscillator

## Section 9 Clock Reset Generator (CRG) Block Description

Consult the CRG Block User Guide for information about the Clock and Reset Generator module.

### 9.1 Device-specific information

The CRG is part of the IPBus domain.

The Low Voltage Reset feature uses the low voltage reset signal from the VREG module as an input to the CRG module. When the regulator output voltage supply to the internal chip logic falls below a specified threshold the LVR signal from the VREG module causes the CRG module to generate a reset. Consult the VREG Block User Guide for voltage level specifications.

### 9.1.1 $\overline{\text{XCLKS}}$

The  $\overline{\text{XCLKS}}$  input signal is active low (see **2.3.8 PE7 / NOACC / XCLKS — Port E I/O Pin 7**).

## Section 10 Oscillator (OSC) Block Description

Consult the OSC Block User Guide for information about the Oscillator module.

## Section 11 Timer (TIM) Block Description

Consult the TIM\_16B8C Block User Guide for information about the Timer module.

## Section 12 Analog to Digital Converter (ATD) Block Description

### 12.1 Device-specific information

#### 12.1.1 VRL (voltage reference low)

In the 48 and 52 pin package versions, the VRL pad is bonded internally to the VSSA pin.

Consult the ATD\_10B8C Block User Guide for further information about the A/D Converter module.

## Section 13 Serial Communications Interface (SCI) Block Description

Consult the SCI Block User Guide for information about the Asynchronous Serial Communications Interface module.

## Section 14 Serial Peripheral Interface (SPI) Block Description

Consult the SPI Block User Guide for information about the Serial Peripheral Interface module.

Consult the SPI Block User Guide for information about the Synchronous Serial Communications Interface module.

## Section 15 Flash Block Description

Consult the FTS16K Block User Guide for information about the Flash module for the MC9S12GC16.

Consult the FTS32K Block User Guide for information about the Flash module for the MC9S12C32 or MC9S12GC32.

Consult the FTS64K Block User Guide for information about the Flash module for the MC9S12C64 or MC9S12GC64.

Consult the FTS96K Block User Guide for information about the Flash module for the MC9S12C96.

Consult the FTS128K Block User Guide for information about the Flash module for the MC9S12C128 or MC9S12GC128.

## Section 16 RAM Block Description

This module supports single-cycle misaligned word accesses without wait states.

The MC912GC16 features a single 1K byte RAM module.

The MC9S12C32 and MC9S12GC32 feature a 2K byte RAM module.

The MC9S12C64, MC9S12GC64, MC9S12C96, MC9S12C128 and MC9S12GC128 versions feature a 4K byte RAM module.

## Section 17 Pulse Width Modulator (PWM) Block Description

Consult the PWM\_8B6C Block User Guide for information about the Pulse Width Modulator Module.

## Section 18 MSCAN Block Description

Consult the MSCAN Block User Guide for information about the Motorola Scalable CAN Module. This module is not available on the MC9GC-Family Members.

## Section 19 Port Integration Module (PIM) Block Description

Consult the PIM\_9C32 Block User Guide for information about the Port Integration Module for all versions of the MC9DS12GC and MC9S12C-Family.

The MODRR register within the PIM allows for mapping of PWM channels to PortT in the absence of PortP pins for the low pin count packages. For the 80QFP package option it is recommended not to use MODRR since this is intended to support PWM channel availability in low pin count packages. Note that when mapping PWM channels to PortT in an 80QFP option, the associated PWM channels are then mapped to both PortP and PortT.

# Appendix A Electrical Characteristics

## A.1 General

**NOTE:** *The electrical characteristics given in this section are preliminary and should be used as a guide only. Values cannot be guaranteed by Motorola and are subject to change without notice.*

**NOTE:** *The parts are specified and tested over the 5V and 3.3V ranges. For the intermediate range, generally the electrical specifications for the 3.3V range apply, but the parts are not tested in production test in the intermediate range.*

This supplement contains the most accurate electrical information for the MC9S12C-Family microcontrollers available at the time of publication. The information should be considered **PRELIMINARY** and is subject to change.

This introduction is intended to give an overview on several common topics like power supply, current injection etc.

### A.1.1 Parameter Classification

The electrical parameters shown in this supplement are guaranteed by various methods. To give the customer a better understanding the following classification is used and the parameters are tagged accordingly in the tables where appropriate.

**NOTE:** *This classification will be added at a later release of the specification*

P: Those parameters are guaranteed during production testing on each individual device.

C: Those parameters are achieved by the design characterization by measuring a statistically relevant sample size across process variations. They are regularly verified by production monitors.

T: Those parameters are achieved by design characterization on a small sample size from typical devices. All values shown in the typical column are within this category.

D: Those parameters are derived mainly from simulations.

### A.1.2 Power Supply

The MC9S12C-Family and MC9S12GC-Family members utilize several pins to supply power to the I/O ports, A/D converter, oscillator and PLL as well as the internal logic.

The VDDA, VSSA pair supplies the A/D converter.

The VDDX, VSSX pair supplies the I/O pins

The VDDR, VSSR pair supplies the internal voltage regulator.

VDD1, VSS1, VDD2 and VSS2 are the supply pins for the digital logic.

VDDPLL, VSSPLL supply the oscillator and the PLL.

VSS1 and VSS2 are internally connected by metal.

VDD1 and VDD2 are internally connected by metal.

VDDA, VDDX, VDDR as well as VSSA, VSSX, VSSR are connected by anti-parallel diodes for ESD protection.

**NOTE:** *In the following context VDD5 is used for either VDDA, VDDR and VDDX; VSS5 is used for either VSSA, VSSR and VSSX unless otherwise noted. IDD5 denotes the sum of the currents flowing into the VDDA, VDDX and VDDR pins. VDD is used for VDD1, VDD2 and VDDPLL, VSS is used for VSS1, VSS2 and VSSPLL. IDD is used for the sum of the currents flowing into VDD1 and VDD2.*

### A.1.3 Pins

There are four groups of functional pins.

#### A.1.3.1 5V I/O pins

Those I/O pins have a nominal level of 5V. This class of pins is comprised of all port I/O pins, the analog inputs, BKGD pin and the RESET inputs. The internal structure of all those pins is identical, however some of the functionality may be disabled. E.g. pull-up and pull-down resistors may be disabled permanently.

#### A.1.3.2 Analog Reference

This class is made up by the two VRH and VRL pins. In 48 and 52 pin package versions the VRL pad is bonded to the VSSA pin.

#### A.1.3.3 Oscillator

The pins XFC, EXTAL, XTAL dedicated to the oscillator have a nominal 2.5V level. They are supplied by VDDPLL.

#### A.1.3.4 TEST

This pin is used for production testing only.

### A.1.4 Current Injection

Power supply must maintain regulation within operating  $V_{DD5}$  or  $V_{DD}$  range during instantaneous and operating maximum current conditions. If positive injection current ( $V_{in} > V_{DD5}$ ) is greater than  $I_{DD5}$ , the injection current may flow out of VDD5 and could result in external power supply going out of regulation. Insure external VDD5 load will shunt current greater than maximum injection current. This will be the greatest risk when the MCU is not consuming power; e.g. if no system clock is present, or if clock rate is very low which would reduce overall power consumption.

## A.1.5 Absolute Maximum Ratings

Absolute maximum ratings are stress ratings only. A functional operation under or outside those maxima is not guaranteed. Stress beyond those limits may affect the reliability or cause permanent damage of the device.

This device contains circuitry protecting against damage due to high static voltage or electrical fields; however, it is advised that normal precautions be taken to avoid application of any voltages higher than maximum-rated voltages to this high-impedance circuit. Reliability of operation is enhanced if unused inputs are tied to an appropriate logic voltage level (e.g., either  $V_{SS5}$  or  $V_{DD5}$ ).

**Table A-1 Absolute Maximum Ratings**

Num	Rating	Symbol	Min	Max	Unit
1	I/O, Regulator and Analog Supply Voltage	$V_{DD5}$	-0.3	6.5	V
2	Digital Logic Supply Voltage <sup>1</sup>	$V_{DD}$	-0.3	3.0	V
3	PLL Supply Voltage <sup>(1)</sup>	$V_{DDPLL}$	-0.3	3.0	V
4	Voltage difference VDDX to VDDR and VDDA	$\Delta V_{DDX}$	-0.3	0.3	V
5	Voltage difference VSSX to VSSR and VSSA	$\Delta V_{SSX}$	-0.3	0.3	V
6	Digital I/O Input Voltage	$V_{IN}$	-0.3	6.5	V
7	Analog Reference	$V_{RH}, V_{RL}$	-0.3	6.5	V
8	XFC, EXTAL, XTAL inputs	$V_{ILV}$	-0.3	3.0	V
9	TEST input	$V_{TEST}$	-0.3	10.0	V
10	Instantaneous Maximum Current Single pin limit for all digital I/O pins <sup>2</sup>	$I_D$	-25	+25	mA
11	Instantaneous Maximum Current Single pin limit for XFC, EXTAL, XTAL <sup>3</sup>	$I_{DL}$	-25	+25	mA
12	Instantaneous Maximum Current Single pin limit for TEST <sup>4</sup>	$I_{DT}$	-0.25	0	mA
13	Operating Temperature Range (packaged)	$T_A$	-40	125	°C
14	Operating Temperature Range (junction)	$T_J$	-40	140	°C
15	Storage Temperature Range	$T_{stg}$	-65	155	°C

**NOTES:**

1. The device contains an internal voltage regulator to generate the logic and PLL supply out of the I/O supply. The absolute maximum ratings apply when the device is powered from an external source.
2. All digital I/O pins are internally clamped to  $V_{SSX}$  and  $V_{DDX}$ ,  $V_{SSR}$  and  $V_{DDR}$  or  $V_{SSA}$  and  $V_{DDA}$ .
3. These pins are internally clamped to  $V_{SSPLL}$  and  $V_{DDPLL}$ .
4. This pin is clamped low to  $V_{SSX}$ , but not clamped high. This pin must be tied low in applications.

## A.1.6 ESD Protection and Latch-up Immunity

All ESD testing is in conformity with CDF-AEC-Q100 Stress test qualification for Automotive Grade Integrated Circuits. During the device qualification ESD stresses were performed for the Human Body Model (HBM), the Machine Model (MM) and the Charge Device Model.

A device will be defined as a failure if after exposure to ESD pulses the device no longer meets the device specification. Complete DC parametric and functional testing is performed per the applicable device specification at room temperature followed by hot temperature, unless specified otherwise in the device specification.

**Table A-2 ESD and Latch-up Test Conditions**

Model	Description	Symbol	Value	Unit
Human Body	Series Resistance	R1	1500	Ohm
	Storage Capacitance	C	100	pF
	Number of Pulse per pin positive negative	-	3 3	
Machine	Series Resistance	R1	0	Ohm
	Storage Capacitance	C	200	pF
	Number of Pulse per pin positive negative	-	3 3	
Latch-up	Minimum input voltage limit		-2.5	V
	Maximum input voltage limit		7.5	V

**Table A-3 ESD and Latch-Up Protection Characteristics**

Num	C	Rating	Symbol	Min	Max	Unit
1	C	Human Body Model (HBM)	$V_{HBM}$	2000	-	V
2	C	Machine Model (MM)	$V_{MM}$	200	-	V
3	C	Charge Device Model (CDM)	$V_{CDM}$	500	-	V
4	C	Latch-up Current at 125°C positive negative	$I_{LAT}$	+100 -100	-	mA
5	C	Latch-up Current at 27°C positive negative	$I_{LAT}$	+200 -200	-	mA

## A.1.7 Operating Conditions

This chapter describes the operating conditions of the devices. Unless otherwise noted those conditions apply to all the following data.

**NOTE:** *Instead of specifying ambient temperature all parameters are specified for the more meaningful silicon junction temperature. For power dissipation calculations refer to Section A.1.8 Power Dissipation and Thermal Characteristics.*

**Table A-4 Operating Conditions**

Rating	Symbol	Min	Typ	Max	Unit
I/O, Regulator and Analog Supply Voltage	$V_{DD5}$	2.97	5	5.5	V
Digital Logic Supply Voltage <sup>1</sup>	$V_{DD}$	2.35	2.5	2.75	V
PLL Supply Voltage <sup>(1)</sup>	$V_{DDPLL}$	2.35	2.5	2.75	V
Voltage Difference VDDX to VDDA	$\Delta V_{DDX}$	-0.1	0	0.1	V
Voltage Difference VSSX to VSSR and VSSA	$\Delta V_{SSX}$	-0.1	0	0.1	V
Oscillator	$f_{osc}$	0.5	-	16	MHz
Bus Frequency	$f_{bus}^2$	0.25	-	25	MHz
Operating Junction Temperature Range	$T_J$	-40	-	140	°C

NOTES:

1. The device contains an internal voltage regulator to generate the logic and PLL supply out of the I/O supply. The absolute maximum ratings apply when this regulator is disabled and the device is powered from an external source.
2. Some blocks e.g. ATD (conversion) and NVMs (program/erase) require higher bus frequencies for proper operation.

## A.1.8 Power Dissipation and Thermal Characteristics

Power dissipation and thermal characteristics are closely related. The user must assure that the maximum operating junction temperature is not exceeded. The average chip-junction temperature ( $T_J$ ) in °C can be obtained from:

$$T_J = T_A + (P_D \cdot \Theta_{JA})$$

$T_J$  = Junction Temperature, [°C]

$T_A$  = Ambient Temperature, [°C]

$P_D$  = Total Chip Power Dissipation, [W]

$\Theta_{JA}$  = Package Thermal Resistance, [°C/W]

The total power dissipation can be calculated from:

$$P_D = P_{INT} + P_{IO}$$

$P_{INT}$  = Chip Internal Power Dissipation, [W]

Two cases with internal voltage regulator enabled and disabled must be considered:

1. Internal Voltage Regulator disabled

$$P_{INT} = I_{DD} \cdot V_{DD} + I_{DDPLL} \cdot V_{DDPLL} + I_{DDA} \cdot V_{DDA}$$

$$P_{IO} = \sum_i R_{DSON} \cdot I_{IO_i}^2$$

Which is the sum of all output currents on I/O ports associated with VDDX and VDDM.

For  $R_{DSON}$  is valid:

$$R_{DSON} = \frac{V_{OL}}{I_{OL}}; \text{for outputs driven low}$$

respectively

$$R_{DSON} = \frac{V_{DD5} - V_{OH}}{I_{OH}}; \text{for outputs driven high}$$

2. Internal voltage regulator enabled

$$P_{INT} = I_{DDR} \cdot V_{DDR} + I_{DDA} \cdot V_{DDA}$$

$I_{DDR}$  is the current shown in Table A-8 and not the overall current flowing into VDDR, which additionally contains the current flowing into the external loads with output high.

$$P_{IO} = \sum_i R_{DSON} \cdot I_{IO_i}^2$$

Which is the sum of all output currents on I/O ports associated with VDDX and VDDR.

**Table A-5 Thermal Package Characteristics<sup>1</sup>**

Num	C	Rating	Symbol	Min	Typ	Max	Unit
1	T	Thermal Resistance LQFP48, single layer PCB <sup>2</sup>	$\theta_{JA}$	-	-	69	°C/W
2	T	Thermal Resistance LQFP48, double sided PCB with 2 internal planes <sup>3</sup>	$\theta_{JA}$	-	-	53	°C/W
3	T	Junction to Board LQFP48	$\theta_{JB}$			30	°C/W
4	T	Junction to Case LQFP48	$\theta_{JC}$			20	°C/W
5	T	Junction to Package Top LQFP48	$\Psi_{JT}$			4	°C/W
6	T	Thermal Resistance LQFP52, single sided PCB	$\theta_{JA}$	-	-	65	°C/W
7	T	Thermal Resistance LQFP52, double sided PCB with 2 internal planes	$\theta_{JA}$	-	-	49	°C/W
8	T	Junction to Board LQFP52	$\theta_{JB}$			31	°C/W
9	T	Junction to Case LQFP52	$\theta_{JC}$			17	°C/W
10	T	Junction to Package Top LQFP52	$\Psi_{JT}$			3	°C/W
11	T	Thermal Resistance QFP 80, single sided PCB	$\theta_{JA}$	-	-	52	°C/W
12	T	Thermal Resistance QFP 80, double sided PCB with 2 internal planes	$\theta_{JA}$	-	-	42	°C/W
13	T	Junction to Board QFP80	$\theta_{JB}$			28	°C/W
14	T	Junction to Case QFP80	$\theta_{JC}$			18	°C/W
15	T	Junction to Package Top QFP80	$\Psi_{JT}$			4	°C/W

NOTES:

1. The values for thermal resistance are achieved by package simulations
2. PC Board according to EIA/JEDEC Standard 51-2
3. PC Board according to EIA/JEDEC Standard 51-7

## A.1.9 I/O Characteristics

This section describes the characteristics of all I/O pins. All parameters are not always applicable, e.g. not all pins feature pull up/down resistances.

Table A-6 5V I/O Characteristics

Conditions are 4.5 < VDDX < 5.5V Temperature from -40°C to +140°C, unless otherwise noted							
Num	C	Rating	Symbol	Min	Typ	Max	Unit
1	P	Input High Voltage	$V_{IH}$	$0.65 \cdot V_{DD5}$	-	-	V
	T	Input High Voltage	$V_{IH}$	-	-	$V_{DD5} + 0.3$	V
2	P	Input Low Voltage	$V_{IL}$	-	-	$0.35 \cdot V_{DD5}$	V
	T	Input Low Voltage	$V_{IL}$	$V_{SS5} - 0.3$	-	-	V
3	C	Input Hysteresis	$V_{HYS}$		250		mV
4	P	Input Leakage Current (pins in high ohmic input mode) <sup>1</sup> $V_{in} = V_{DD5}$ or $V_{SS5}$	$I_{in}$	-1	-	1	$\mu A$
5	C	Output High Voltage (pins in output mode) Partial Drive $I_{OH} = -2mA$	$V_{OH}$	$V_{DD5} - 0.8$	-	-	V
6	P	Output High Voltage (pins in output mode) Full Drive $I_{OH} = -10mA$	$V_{OH}$	$V_{DD5} - 0.8$	-	-	V
7	C	Output Low Voltage (pins in output mode) Partial Drive $I_{OL} = +2mA$	$V_{OL}$	-	-	0.8	V
8	P	Output Low Voltage (pins in output mode) Full Drive $I_{OL} = +10mA$	$V_{OL}$	-	-	0.8	V
9	P	Internal Pull Up Device Current, tested at $V_{IL}$ Max.	$I_{PUL}$	-	-	-130	$\mu A$
10	C	Internal Pull Up Device Current, tested at $V_{IH}$ Min.	$I_{PUH}$	-10	-	-	$\mu A$
11	P	Internal Pull Down Device Current, tested at $V_{IH}$ Min.	$I_{PDH}$	-	-	130	$\mu A$
12	C	Internal Pull Down Device Current, tested at $V_{IL}$ Max.	$I_{PDL}$	10	-	-	$\mu A$
13	D	Input Capacitance	$C_{in}$		7	-	pF
14	T	Injection current <sup>2</sup> Single Pin limit Total Device Limit. Sum of all injected currents	$I_{ICS}$ $I_{ICP}$	-2.5 -25	-	2.5 25	mA
15	P	Port P, J Interrupt Input Pulse filtered <sup>3</sup>	$t_{PIGN}$			3	$\mu s$
16	P	Port P, J Interrupt Input Pulse passed <sup>3</sup>	$t_{PVAL}$	10			$\mu s$

## NOTES:

1. Maximum leakage current occurs at maximum operating temperature. Current decreases by approximately one-half for each 8 C to 12 C in the temperature range from 50 C to 125 C.
2. Refer to **Section A.1.4 Current Injection**, for more details
3. Parameter only applies in STOP or Pseudo STOP mode.

**Table A-7 3.3V I/O Characteristics**

Conditions are VDDX=3.3V +/-10%, Temperature from -40°C to +140°C, unless otherwise noted							
Num	C	Rating	Symbol	Min	Typ	Max	Unit
1	P	Input High Voltage	$V_{IH}$	$0.65 \cdot V_{DD5}$	-	-	V
	T	Input High Voltage	$V_{IH}$	-	-	$V_{DD5} + 0.3$	V
2	P	Input Low Voltage	$V_{IL}$	-	-	$0.35 \cdot V_{DD5}$	V
	T	Input Low Voltage	$V_{IL}$	$V_{SS5} - 0.3$	-	-	V
3	C	Input Hysteresis	$V_{HYS}$		250		mV
4	P	Input Leakage Current (pins in high ohmic input mode) <sup>1</sup> $V_{in} = V_{DD5}$ or $V_{SS5}$	$I_{in}$	-1	-	1	$\mu A$
5	C	Output High Voltage (pins in output mode) Partial Drive $I_{OH} = -0.75mA$	$V_{OH}$	$V_{DD5} - 0.4$	-	-	V
6	P	Output High Voltage (pins in output mode) Full Drive $I_{OH} = -4mA$	$V_{OH}$	$V_{DD5} - 0.4$	-	-	V
7	C	Output Low Voltage (pins in output mode) Partial Drive $I_{OL} = +0.9mA$	$V_{OL}$	-	-	0.4	V
8	P	Output Low Voltage (pins in output mode) Full Drive $I_{OL} = +4.75mA$	$V_{OL}$	-	-	0.4	V
9	P	Internal Pull Up Device Current, tested at $V_{IL}$ Max.	$I_{PUL}$	-	-	-60	$\mu A$
10	C	Internal Pull Up Device Current, tested at $V_{IH}$ Min.	$I_{PUH}$	-6	-	-	$\mu A$
11	P	Internal Pull Down Device Current, tested at $V_{IH}$ Min.	$I_{PDH}$	-	-	60	$\mu A$
12	C	Internal Pull Down Device Current, tested at $V_{IL}$ Max.	$I_{PDL}$	6	-	-	$\mu A$
11	D	Input Capacitance	$C_{in}$		7	-	pF
12	T	Injection current <sup>2</sup> Single Pin limit Total Device Limit. Sum of all injected currents	$I_{ICS}$ $I_{ICP}$	-2.5 -25	-	2.5 25	mA
13	P	Port P, J Interrupt Input Pulse filtered <sup>3</sup>	$t_{PIGN}$			3	$\mu s$
14	P	Port P, J Interrupt Input Pulse passed <sup>3</sup>	$t_{PVAL}$	10			$\mu s$

## NOTES:

- Maximum leakage current occurs at maximum operating temperature. Current decreases by approximately one-half for each 8 C to 12 C in the temperature range from 50 C to 125 C.
- Refer to **Section A.1.4 Current Injection**, for more details
- Parameter only applies in STOP or Pseudo STOP mode.

## A.1.10 Supply Currents

This section describes the current consumption characteristics of the device as well as the conditions for the measurements.

### A.1.10.1 Measurement Conditions

All measurements are without output loads. Unless otherwise noted the currents are measured in single chip mode, internal voltage regulator enabled and at 25MHz bus frequency using a 4MHz oscillator.

### A.1.10.2 Additional Remarks

In expanded modes the currents flowing in the system are highly dependent on the load at the address, data and control signals as well as on the duty cycle of those signals. No generally applicable numbers can be given. A very good estimate is to take the single chip currents and add the currents due to the external loads.

Table A-8 Supply Current Characteristics for MC9S12C32

Conditions are shown in Table A-4 with internal regulator enabled unless otherwise noted							
Num	C	Rating	Symbol	Min	Typ	Max	Unit
1	P	Run Supply Current Single Chip	$I_{DD5}$			35	mA
2	P P C	Wait Supply current All modules enabled VDDR<4.9V, only RTI enabled <sup>(2)</sup> VDDR>4.9V, only RTI enabled	$I_{DDW}$		3.5 2.5	30 8	mA
3	C P C P C P C P	Pseudo Stop Current (RTI and COP disabled) <sup>(2)(3)</sup> -40°C 27°C 85°C "C" Temp Option 100°C 105°C "V" Temp Option 120°C 125°C "M" Temp Option 140°C	$I_{DDPS}^1$		340 360 500 550 590 720 780 1100	450 1450 1900 4500	μA
4	C C C C C	Pseudo Stop Current (RTI and COP enabled) <sup>2 3</sup> -40°C 27°C 85°C 105°C 125°C	$I_{DDPS}^1$		540 700 750 880 1300		μA
5	C P C P C P C P	Stop Current <sup>(3)</sup> -40°C 27°C 85°C "C" Temp Option 100°C 105°C "V" Temp Option 120°C 125°C "M" Temp Option 140°C	$I_{DDS}^{(1)}$		10 20 100 140 170 300 350 520	80 1000 1400 4000	μA

## NOTES:

- STOP current measured in production test at increased junction temperature, hence for Temp Option "C" the test is carried out at 100°C although the Temperature specification is 85°C. Similarly for "v" and "M" options the temperature used in test lies 15°C above the temperature option specification.
- PLL off
- At those low power dissipation levels  $T_J = T_A$  can be assumed

**Table A-9 Supply Current Characteristics for MC9S12C64,MC9S12C96,MC9S12C128**

Conditions are shown in Table A-4 with internal regulator enabled unless otherwise noted							
Num	C	Rating	Symbol	Min	Typ	Max	Unit
1	P	Run Supply Current Single Chip,	$I_{DD5}$			45	mA
2	P P C	Wait Supply current All modules enabled VDDR<4.9V, only RTI enabled <sup>(2)</sup> VDDR>4.9V, only RTI enabled	$I_{DDW}$		2.5 3.5	33 8	mA
6	C P C P C P C P	Pseudo Stop Current (RTI and COP disabled) <sup>(2)(3)</sup> -40°C 27°C 85°C "C" Temp Option 100°C 105°C "V" Temp Option 120°C 125°C "M" Temp Option 140°C	$I_{DDPS}^1$		190 200 300 400 450 600 650 1000	250 1400 1900 4800	μA
4	C C C C C	Pseudo Stop Current (RTI and COP enabled) <sup>2 3</sup> -40°C 27°C 85°C 105°C 125°C	$I_{DDPS}^1$		370 500 590 780 1200		μA
5	C P C P C P C P	Stop Current <sup>(3)</sup> -40°C 27°C 85°C "C" Temp Option 100°C 105°C "V" Temp Option 120°C 125°C "M" Temp Option 140°C	$I_{DD5}^{(1)}$		12 25 130 160 200 350 400 600	100 1200 1700 4500	μA

NOTES:

1. STOP current measured in production test at increased junction temperature, hence for Temp Option "C" the test is carried out at 100°C although the Temperature specification is 85°C. Similarly for "v" and "M" options the temperature used in test lies 15°C above the temperature option specification.
2. PLL off
3. At those low power dissipation levels  $T_J = T_A$  can be assumed

## Appendix B Electrical Specifications

### B.1 Voltage Regulator Operating Conditions

Table B-1 Voltage Regulator Electrical Parameters

Num	C	Characteristic	Symbol	Min	Typical	Max	Unit
1	P	Input Voltages	$V_{VDDR, A}$	2.97	—	5.5	V
2	C	Regulator Current Reduced Power Mode Shutdown Mode	$I_{REG}$	— —	20 12	50 40	$\mu A$ $\mu A$
3	P	Output Voltage Core Full Performance Mode	$V_{DD}$	2.35	2.5	2.75	V
4	P	Low Voltage Interrupt <sup>1</sup> Assert Level C32, GC32 Assert Level C64, C96, C128 GC64, GC128 Deassert Level C32, GC32 Deassert Level C64, C96, C128 GC64, GC128	$V_{LVIA}$ $V_{LVIA}$ $V_{LVID}$ $V_{LVID}$	4.30 4.10 4.42 4.25	4.53 4.37 4.65 4.52	4.77 4.66 4.89 4.77	V V V V
5	P	Low Voltage Reset <sup>2</sup> Assert Level C32, GC32 Assert Level C64, C96, C128 GC64, GC128	$V_{LVRA}$	2.25 2.25	2.3 2.35	—	V
6	P	Low Voltage Reset <sup>(2)</sup> Deassert Level	$V_{LVRD}$	—	—	2.55	V
7	C	Power-on Reset <sup>3</sup> Assert Level Deassert Level	$V_{PORA}$ $V_{PORD}$	0.97 —	— —	— 2.05	V V

NOTES:

1. Monitors  $V_{DDA}$ , active only in Full Performance Mode. Indicates I/O & ADC performance degradation due to low supply voltage.
2. Monitors  $V_{DD}$ , active only in Full Performance Mode. MCU is monitored by the POR in RPM (see **Figure B-1**)
3. Monitors  $V_{DD}$ . Active in all modes.

**NOTE:** *The electrical characteristics given in this section are preliminary and should be used as a guide only. Values in this section cannot be guaranteed by Motorola and are subject to change without notice.*

## B.2 Chip Power-up and LVI/LVR graphical explanation

Voltage regulator sub modules LVI (low voltage interrupt), POR (power-on reset) and LVR (low voltage reset) handle chip power-up or drops of the supply voltage. Their function is described in **Figure B-1**.

**Figure B-1 Voltage Regulator - Chip Power-up and Voltage Drops (not scaled)**

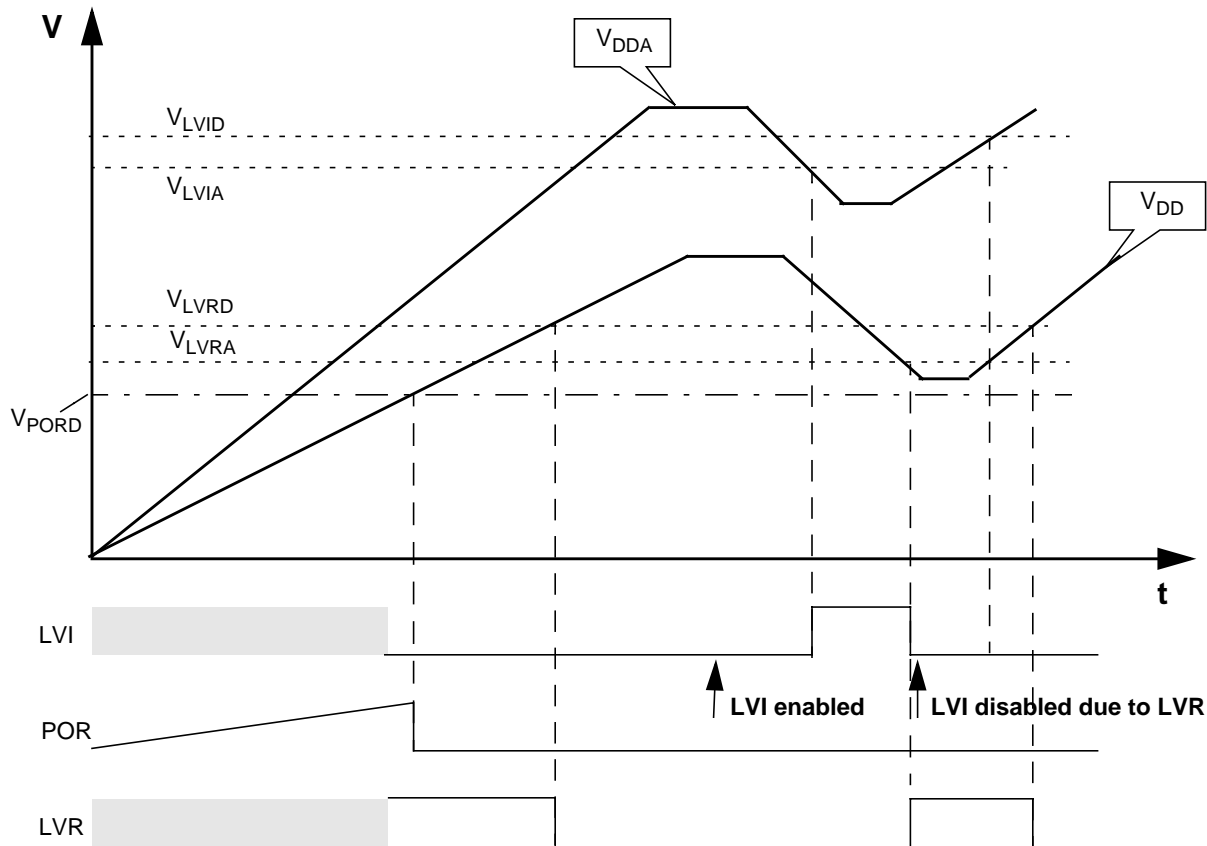

## B.3 Output Loads

### B.3.1 Resistive Loads

The on-chip voltage regulator is intended to supply the internal logic and oscillator circuits allows no external DC loads.

## B.3.2 Capacitive Loads

The capacitive loads are specified in **Table B-2**. Ceramic capacitors with X7R dielectricum are required.

**Table B-2 Voltage Regulator - Capacitive Loads**

Num	Characteristic	Symbol	Min	Typical	Max	Unit
1	VDD external capacitive load	$C_{DDext}$	400	440	12000	nF
2	VDDPLL external capacitive load	$C_{DDPLLext}$	90	220	5000	nF



## B.4 ATD Characteristics

This section describes the characteristics of the analog to digital converter.

VRL is not available as a separate pin in the 48 and 52 pin versions. In this case the internal VRL pad is bonded to the VSSA pin.

The ATD is specified and tested for both the 3.3V and 5V range. For ranges between 3.3V and 5V the ATD accuracy is generally the same as in the 3.3V range but is not tested in this range in production test.

### B.4.1 ATD Operating Characteristics In 5V Range

The Table B-3 shows conditions under which the ATD operates.

The following constraints exist to obtain full-scale, full range results:

$V_{SSA} \leq V_{RL} \leq V_{IN} \leq V_{RH} \leq V_{DDA}$ . This constraint exists since the sample buffer amplifier can not drive beyond the power supply levels that it ties to. If the input level goes outside of this range it will effectively be clipped.

**Table B-3 ATD Operating Characteristics**

Conditions are shown in Table A-4 unless otherwise noted. Supply Voltage $5V-10\% \leq V_{DDA} \leq 5V+10\%$							
Num	C	Rating	Symbol	Min	Typ	Max	Unit
1	D	Reference Potential Low High	VRL VRH	VSSA VDDA/2		VDDA/2 VDDA	V V
2	C	Differential Reference Voltage <sup>1</sup>	VRH-VRL	4.75	5.0	5.25	V
3	D	ATD Clock Frequency	$f_{ATDCLK}$	0.5		2.0	MHz
4	D	ATD 10-Bit Conversion Period Clock Cycles <sup>2</sup> Conv, Time at 2.0MHz ATD Clock $f_{ATDCLK}$	$N_{CONV10}$ $T_{CONV10}$	14 7		28 14	Cycles $\mu s$
5	D	ATD 8-Bit Conversion Period Clock Cycles <sup>2</sup> Conv, Time at 2.0MHz ATD Clock $f_{ATDCLK}$	$N_{CONV10}$ $T_{CONV10}$	12 6		26 13	Cycles $\mu s$
5	D	Recovery Time ( $V_{DDA}=5.0$ Volts)	$t_{REC}$			20	$\mu s$
6	P	Reference Supply current	$I_{REF}$			0.375	mA

NOTES:

1. Full accuracy is not guaranteed when differential voltage is less than 4.75V
2. The minimum time assumes a final sample period of 2 ATD clocks cycles while the maximum time assumes a final sample period of 16 ATD clocks.

### B.4.2 ATD Operating Characteristics In 3.3V Range

The Table B-3 shows conditions under which the ATD operates.

The following constraints exist to obtain full-scale, full range results:

$V_{SSA} \leq V_{RL} \leq V_{IN} \leq V_{RH} \leq V_{DDA}$ . This constraint exists since the sample buffer amplifier can not drive

beyond the power supply levels that it ties to. If the input level goes outside of this range it will effectively be clipped

**Table B-4 ATD Operating Characteristics**

Conditions are shown in Table A-4 unless otherwise noted; Supply Voltage $3.3V-10\% \leq V_{DDA} \leq 3.3V+10\%$							
Num	C	Rating	Symbol	Min	Typ	Max	Unit
1	D	Reference Potential Low High	$V_{RL}$ $V_{RH}$	$V_{SSA}$ $V_{DDA}/2$		$V_{DDA}/2$ $V_{DDA}$	V V
2	C	Differential Reference Voltage	$V_{RH}-V_{RL}$	3.0	3.3	3.6	V
3	D	ATD Clock Frequency	$f_{ATDCLK}$	0.5		2.0	MHz
4	D	ATD 10-Bit Conversion Period Clock Cycles <sup>1</sup> Conv, Time at 2.0MHz ATD Clock $f_{ATDCLK}$	$N_{CONV10}$ $T_{CONV10}$	14 7		28 14	Cycles $\mu s$
5	D	ATD 8-Bit Conversion Period Clock Cycles <sup>(1)</sup> Conv, Time at 2.0MHz ATD Clock $f_{ATDCLK}$	$N_{CONV8}$ $T_{CONV8}$	12 6		26 13	Cycles $\mu s$
6	D	Recovery Time ( $V_{DDA}=3.3$ Volts)	$t_{REC}$			20	$\mu s$
7	P	Reference Supply current	$I_{REF}$			0.250	mA

NOTES:

1. The minimum time assumes a final sample period of 2 ATD clocks cycles while the maximum time assumes a final sample period of 16 ATD clocks.

### B.4.3 Factors influencing accuracy

Three factors - source resistance, source capacitance and current injection - have an influence on the accuracy of the ATD.

#### B.4.3.1 Source Resistance:

Due to the input pin leakage current as specified in Table A-6 in conjunction with the source resistance there will be a voltage drop from the signal source to the ATD input. The maximum source resistance  $R_S$  specifies results in an error of less than 1/2 LSB (2.5mV) at the maximum leakage current. If device or operating conditions are less than worst case or leakage-induced error is acceptable, larger values of source resistance is allowable.

#### B.4.3.2 Source capacitance

When sampling an additional internal capacitor is switched to the input. This can cause a voltage drop due to charge sharing with the external and the pin capacitance. For a maximum sampling error of the input voltage  $\leq 1LSB$ , then the external filter capacitor,  $C_f \geq 1024 * (C_{INS} - C_{INN})$ .

### B.4.3.3 Current injection

There are two cases to consider.

1. A current is injected into the channel being converted. The channel being stressed has conversion values of \$3FF (\$FF in 8-bit mode) for analog inputs greater than VRH and \$000 for values less than VRL unless the current is higher than specified as disruptive conditions.
2. Current is injected into pins in the neighborhood of the channel being converted. A portion of this current is picked up by the channel (coupling ratio K), This additional current impacts the accuracy of the conversion depending on the source resistance.

The additional input voltage error on the converted channel can be calculated as  $V_{ERR} = K * R_S * I_{INJ}$ , with  $I_{INJ}$  being the sum of the currents injected into the two pins adjacent to the converted channel.

**Table B-5 ATD Electrical Characteristics**

Conditions are shown in Table A-4 unless otherwise noted							
Num	C	Rating	Symbol	Min	Typ	Max	Unit
1	C	Max input Source Resistance	$R_S$	-	-	1	K $\Omega$
2	T	Total Input Capacitance Non Sampling Sampling	$C_{INN}$ $C_{INS}$			10 15	pF
3	C	Disruptive Analog Input Current	$I_{NA}$	-2.5		2.5	mA
4	C	Coupling Ratio positive current injection	$K_p$			$10^{-4}$	A/A
5	C	Coupling Ratio negative current injection	$K_n$			$10^{-2}$	A/A

## B.4.4 ATD accuracy (5V Range)

Table B-6 specifies the ATD conversion performance excluding any errors due to current injection, input capacitance and source resistance.

**Table B-6 ATD Conversion Performance**

Conditions are shown in Table A-4 unless otherwise noted $V_{REF} = V_{RH} - V_{RL} = 5.12V$ . Resulting to one 8 bit count = 20mV and one 10 bit count = 5mV $f_{ATDCLK} = 2.0MHz$							
Num	C	Rating	Symbol	Min	Typ	Max	Unit
1	P	10-Bit Resolution	LSB		5		mV
2	P	10-Bit Differential Nonlinearity	DNL	-1		1	Counts
3	P	10-Bit Integral Nonlinearity	INL	-2		2	Counts
4	P	10-Bit Absolute Error <sup>1</sup>	AE	-2.5		2.5	Counts
5	P	8-Bit Resolution	LSB		20		mV
6	P	8-Bit Differential Nonlinearity	DNL	-0.5		0.5	Counts
7	P	8-Bit Integral Nonlinearity	INL	-1.0	±0.5	1.0	Counts
8	P	8-Bit Absolute Error <sup>(1)</sup>	AE	-1.5	±1	1.5	Counts

NOTES:

1. These values include quantization error which is inherently 1/2 count for any A/D converter.

## B.4.5 ATD accuracy (3.3V Range)

Table B-6 specifies the ATD conversion performance excluding any errors due to current injection, input capacitance and source resistance.

**Table B-7 ATD Conversion Performance**

Conditions are shown in Table A-4 unless otherwise noted $V_{REF} = V_{RH} - V_{RL} = 3.328V$ . Resulting to one 8 bit count = 13mV and one 10 bit count = 3.25mV $f_{ATDCLK} = 2.0MHz$							
Num	C	Rating	Symbol	Min	Typ	Max	Unit
1	P	10-Bit Resolution	LSB		3.25		mV
2	P	10-Bit Differential Nonlinearity	DNL	-1.5		1.5	Counts
3	P	10-Bit Integral Nonlinearity	INL	-3.5	±1.5	3.5	Counts
4	P	10-Bit Absolute Error <sup>1</sup>	AE	-5	±2.5	5	Counts
5	P	8-Bit Resolution	LSB		13		mV
6	P	8-Bit Differential Nonlinearity	DNL	-0.5		0.5	Counts
7	P	8-Bit Integral Nonlinearity	INL	-1.5	±1	1.5	Counts
8	P	8-Bit Absolute Error <sup>(1)</sup>	AE	-2.0	±1.5	2.0	Counts

NOTES:

1. These values include the quantization error which is inherently 1/2 count for any A/D converter.

For the following definitions see also **Figure B-2**.

Differential Non-Linearity (DNL) is defined as the difference between two adjacent switching steps.

$$\text{DNL}(i) = \frac{V_i - V_{i-1}}{1\text{LSB}} - 1$$

The Integral Non-Linearity (INL) is defined as the sum of all DNLs:

$$\text{INL}(n) = \sum_{i=1}^n \text{DNL}(i) = \frac{V_n - V_0}{1\text{LSB}} - n$$

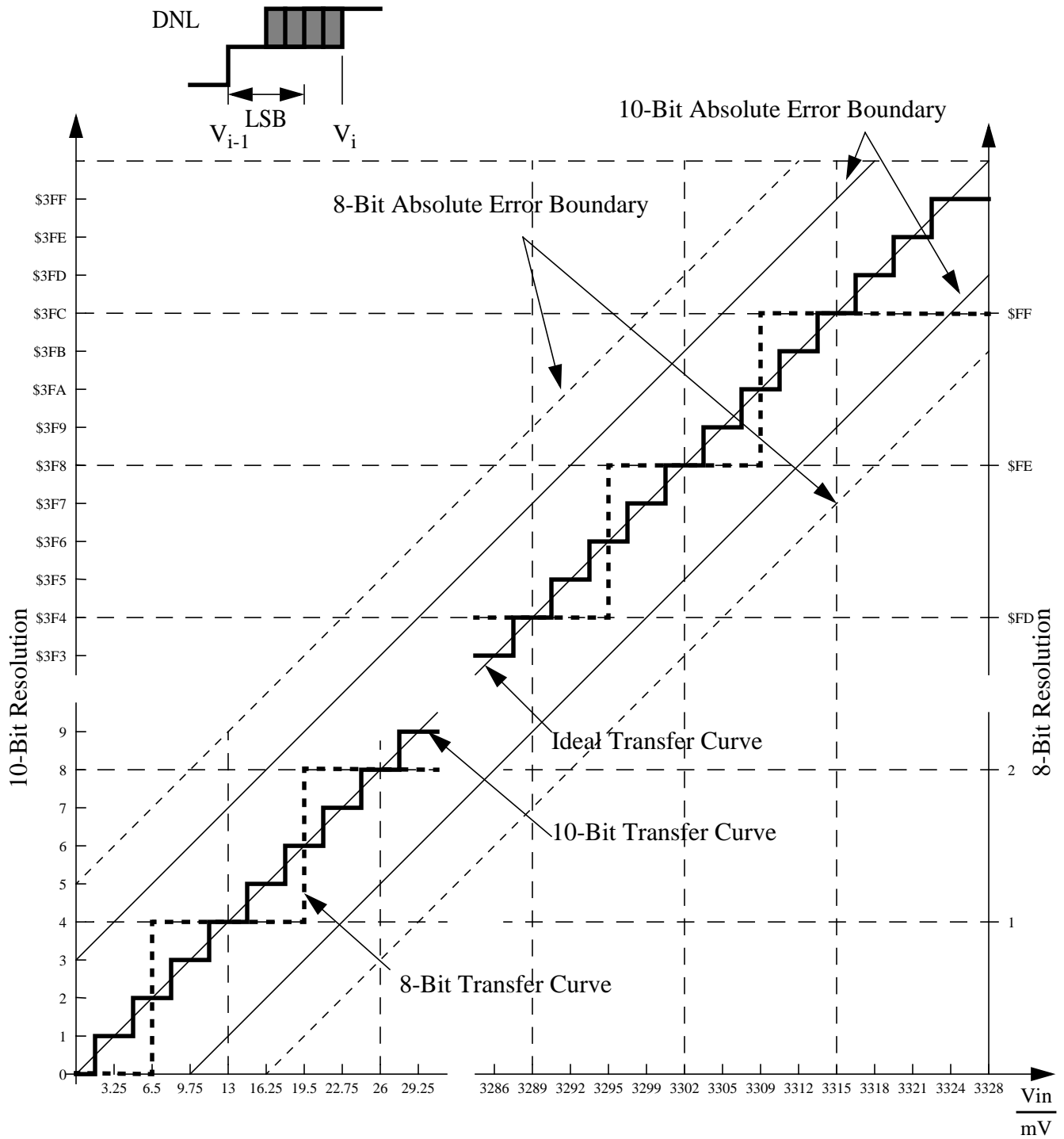

Figure B-2 ATD Accuracy Definitions

**NOTE:** Figure B-2 shows only definitions, for specification values refer to Table B-6.

## B.5 NVM, Flash and EEPROM

### B.5.1 NVM timing

The time base for all NVM program or erase operations is derived from the oscillator. A minimum oscillator frequency  $f_{\text{NVMOSC}}$  is required for performing program or erase operations. The NVM modules do not have any means to monitor the frequency and will not prevent program or erase operation at frequencies above or below the specified minimum. Attempting to program or erase the NVM modules at a lower frequency a full program or erase transition is not assured.

The Flash program and erase operations are timed using a clock derived from the oscillator using the FCLKDIV and ECLKDIV registers respectively. The frequency of this clock must be set within the limits specified as  $f_{\text{NVMOP}}$ .

The minimum program and erase times shown in Table B-8 are calculated for maximum  $f_{\text{NVMOP}}$  and maximum  $f_{\text{bus}}$ . The maximum times are calculated for minimum  $f_{\text{NVMOP}}$  and a  $f_{\text{bus}}$  of 2MHz.

#### B.5.1.1 Single Word Programming

The programming time for single word programming is dependant on the bus frequency as a well as on the frequency  $f_{\text{NVMOP}}$  and can be calculated according to the following formula.

$$t_{\text{swpgm}} = 9 \cdot \frac{1}{f_{\text{NVMOP}}} + 25 \cdot \frac{1}{f_{\text{bus}}}$$

#### B.5.1.2 Burst Programming

This applies only to the Flash where up to 32 words in a row can be programmed consecutively using burst programming by keeping the command pipeline filled. The time to program a consecutive word can be calculated as:

$$t_{\text{bwpgm}} = 4 \cdot \frac{1}{f_{\text{NVMOP}}} + 9 \cdot \frac{1}{f_{\text{bus}}}$$

The time to program a whole row is:

$$t_{\text{brpgm}} = t_{\text{swpgm}} + 31 \cdot t_{\text{bwpgm}}$$

Burst programming is more than 2 times faster than single word programming.

#### B.5.1.3 Sector Erase

Erasing a 512 byte Flash sector takes:

$$t_{\text{era}} \approx 4000 \cdot \frac{1}{f_{\text{NVMOP}}}$$

The setup times can be ignored for this operation.

### B.5.1.4 Mass Erase

Erasing a NVM block takes:

$$t_{\text{mass}} \approx 20000 \cdot \frac{1}{f_{\text{NVMOP}}}$$

The setup times can be ignored for this operation.

**Table B-8 NVM Timing Characteristics**

Conditions are shown in Table A-4 unless otherwise noted							
Num	C	Rating	Symbol	Min	Typ	Max	Unit
1	D	External Oscillator Clock	$f_{\text{NVMOSC}}$	0.5		50 <sup>1</sup>	MHz
2	D	Bus frequency for Programming or Erase Operations	$f_{\text{NVMBUS}}$	1			MHz
3	D	Operating Frequency	$f_{\text{NVMOP}}$	150		200	kHz
4	P	Single Word Programming Time	$t_{\text{swpgm}}$	46 <sup>2</sup>		74.5 <sup>3</sup>	μs
5	D	Flash Burst Programming consecutive word	$t_{\text{bwpgm}}$	20.4 <sup>2</sup>		31 <sup>3</sup>	μs
6	D	Flash Burst Programming Time for 32 Words	$t_{\text{brpgm}}$	678.4 <sup>2</sup>		1035.5 <sup>3</sup>	μs
7	P	Sector Erase Time	$t_{\text{era}}$	20 <sup>4</sup>		26.7 <sup>3</sup>	ms
8	P	Mass Erase Time	$t_{\text{mass}}$	100 <sup>4</sup>		133 <sup>3</sup>	ms
9	D	Blank Check Time Flash per block	$t_{\text{check}}$	11 <sup>5</sup>		32778 <sup>6</sup>	$t_{\text{cyc}}$

**NOTES:**

1. Restrictions for oscillator in crystal mode apply!
2. Minimum Programming times are achieved under maximum NVM operating frequency  $f_{\text{NVMOP}}$  and maximum bus frequency  $f_{\text{bus}}$ .
3. Maximum Erase and Programming times are achieved under particular combinations of  $f_{\text{NVMOP}}$  and bus frequency  $f_{\text{bus}}$ . Refer to formulae in Sections A.3.1.1 - A.3.1.4 for guidance.
4. Minimum Erase times are achieved under maximum NVM operating frequency  $f_{\text{NVMOP}}$ .
5. Minimum time, if first word in the array is not blank
6. Maximum time to complete check on an erased block.

### B.5.2 NVM Reliability

The reliability of the NVM blocks is guaranteed by stress test during qualification, constant process monitors and burn-in to screen early life failures.

The failure rates for data retention and program/erase cycling are specified at <2ppm defects over lifetime at the operating conditions noted.

A program/erase cycle is specified as two transitions of the cell value from erased → programmed → erased, 1 → 0 → 1.

**NOTE:** All values shown in Table B-9 are target values and subject to further extensive characterization.

**Table B-9 NVM Reliability Characteristics**

Conditions are shown in Table A-4 unless otherwise noted							
Num	C	Rating	Symbol	Min	Typ	Max	Unit
1	C	Data Retention at an average junction temperature of $T_{Javg} = 85^{\circ}\text{C}$	$t_{NVMRET}$	15			Years
2	C	Flash number of Program/Erase cycles	$n_{FLPE}$	10,000			Cycles



## B.6 Reset, Oscillator and PLL

This section summarizes the electrical characteristics of the various startup scenarios for Oscillator and Phase-Locked-Loop (PLL).

### B.6.1 Startup

Table B-10 summarizes several startup characteristics explained in this section. Detailed description of the startup behavior can be found in the Clock and Reset Generator (CRG) Block User Guide.

**Table B-10 Startup Characteristics**

Conditions are shown in Table A-4 unless otherwise noted							
Num	C	Rating	Symbol	Min	Typ	Max	Unit
1	T	POR release level	$V_{PORR}$			2.07	V
2	T	POR assert level	$V_{PORA}$	0.97			V
3	D	Reset input pulse width, minimum input time	$PW_{RSTL}$	2			$t_{osc}$
4	D	Startup from Reset	$n_{RST}$	192		196	$n_{osc}$
5	D	Interrupt pulse width, $\overline{IRQ}$ edge-sensitive mode	$PW_{IRQ}$	20			ns
6	D	Wait recovery startup time	$t_{WRS}$			14	$t_{cyc}$

#### B.6.1.1 POR

The release level  $V_{PORR}$  and the assert level  $V_{PORA}$  are derived from the  $V_{DD}$  Supply. They are also valid if the device is powered externally. After releasing the POR reset the oscillator and the clock quality check are started. If after a time  $t_{CQOUT}$  no valid oscillation is detected, the MCU will start using the internal self clock. The fastest startup time possible is given by  $n_{uposc}$ .

#### B.6.1.2 LVR

The release level  $V_{LVRR}$  and the assert level  $V_{LVRA}$  are derived from the  $V_{DD}$  Supply. They are also valid if the device is powered externally. After releasing the LVR reset the oscillator and the clock quality check are started. If after a time  $t_{CQOUT}$  no valid oscillation is detected, the MCU will start using the internal self clock. The fastest startup time possible is given by  $n_{uposc}$ .

#### B.6.1.3 SRAM Data Retention

Provided an appropriate external reset signal is applied to the MCU, preventing the CPU from executing code when  $V_{DD5}$  is out of specification limits, the SRAM contents integrity is guaranteed if after the reset the PORF bit in the CRG Flags Register has not been set.

#### B.6.1.4 External Reset

When external reset is asserted for a time greater than  $PW_{RSTL}$  the CRG module generates an internal reset, and the CPU starts fetching the reset vector without doing a clock quality check, if there was an oscillation before reset.

#### B.6.1.5 Stop Recovery

Out of STOP the controller can be woken up by an external interrupt. A clock quality check as after POR is performed before releasing the clocks to the system.

#### B.6.1.6 Pseudo Stop and Wait Recovery

The recovery from Pseudo STOP and Wait are essentially the same since the oscillator was not stopped in both modes. The controller can be woken up by internal or external interrupts. After  $t_{wrs}$  the CPU starts fetching the interrupt vector.

### B.6.2 Oscillator

The device features an internal Colpitts oscillator. By asserting the  $\overline{XCLKS}$  input during reset this oscillator can be bypassed allowing the input of a square wave. Before asserting the oscillator to the internal system clocks the quality of the oscillation is checked for each start from either power-on, STOP or oscillator fail.  $t_{CQOUT}$  specifies the maximum time before switching to the internal self clock mode in case no proper oscillation is detected. The quality monitor also determines the minimum oscillator start-up

time  $t_{UPOSC}$ . The device features a clock monitor. A time-out is asserted if the frequency of the incoming clock signal is below the Clock Monitor Failure Assert Frequency  $f_{CMFA}$ .

**Table B-11 Oscillator Characteristics**

Conditions are shown in Table A-4 unless otherwise noted							
Num	C	Rating	Symbol	Min	Typ	Max	Unit
1a	C	Crystal oscillator range (Colpitts)	$f_{OSC}$	0.5		16	MHz
1b	C	Crystal oscillator range (Pierce) <sup>1(4)</sup>	$f_{OSC}$	0.5		40	MHz
2	P	Startup Current	$i_{OSC}$	100			$\mu A$
3	C	Oscillator start-up time (Colpitts)	$t_{UPOSC}$		$g^2$	$100^3$	ms
4	D	Clock Quality check time-out	$t_{CQOUT}$	0.45		2.5	s
5	P	Clock Monitor Failure Assert Frequency	$f_{CMFA}$	50	100	200	KHz
6	P	External square wave input frequency <sup>4</sup>	$f_{EXT}$	0.5		50	MHz
7	D	External square wave pulse width low	$t_{EXTL}$	9.5			ns
8	D	External square wave pulse width high	$t_{EXTH}$	9.5			ns
9	D	External square wave rise time	$t_{EXTR}$			1	ns
10	D	External square wave fall time	$t_{EXTF}$			1	ns
11	D	Input Capacitance (EXTAL, XTAL pins)	$C_{IN}$		7		pF
12	C	DC Operating Bias in Colpitts Configuration on EXTAL Pin	$V_{DCBIAS}$		1.1		V

NOTES:

1. Depending on the crystal a damping series resistor might be necessary
2.  $f_{osc} = 4\text{MHz}$ ,  $C = 22\text{pF}$ .
3. Maximum value is for extreme cases using high Q, low frequency crystals
4.  $XCLKS = 0$  during reset

## B.6.3 Phase Locked Loop

The oscillator provides the reference clock for the PLL. The PLL's Voltage Controlled Oscillator (VCO) is also the system clock source in self clock mode.

### B.6.3.1 XFC Component Selection

This section describes the selection of the XFC components to achieve a good filter characteristics.

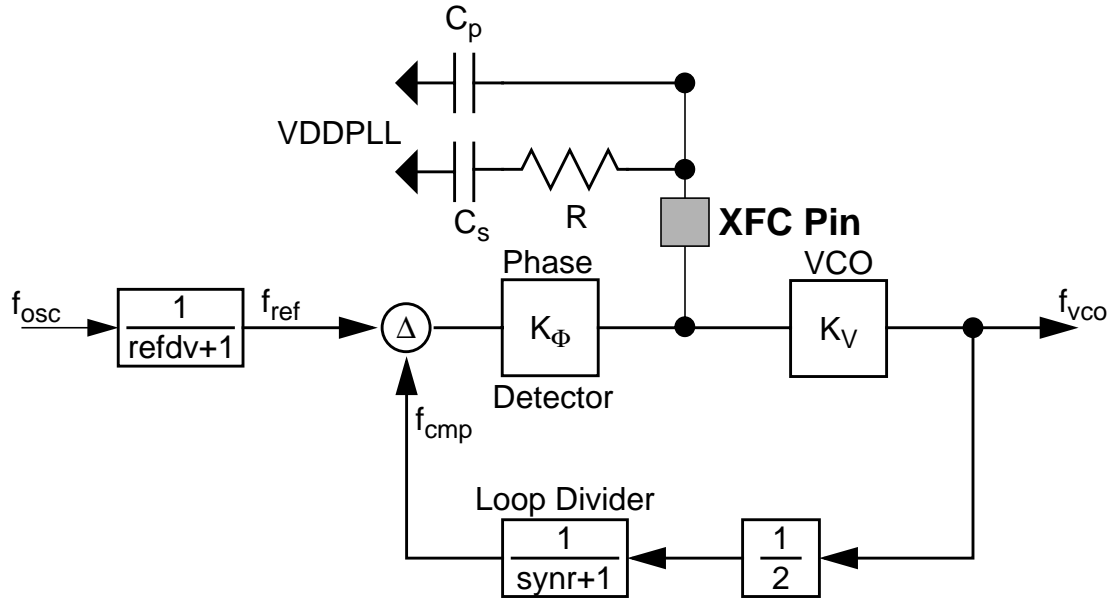

**Figure B-3 Basic PLL functional diagram**

The following procedure can be used to calculate the resistance and capacitance values using typical values for  $K_1$ ,  $f_1$  and  $i_{ch}$  from Table B-12.

The grey boxes show the calculation for  $f_{VCO} = 50\text{MHz}$  and  $f_{ref} = 1\text{MHz}$ . E.g., these frequencies are used for  $f_{OSC} = 4\text{MHz}$  and a  $25\text{MHz}$  bus clock.

The VCO Gain at the desired VCO frequency is approximated by:

$$K_V = K_1 \cdot e^{\frac{(f_1 - f_{VCO})}{K_1 \cdot 1V}} = -100 \cdot e^{\frac{(60 - 50)}{-100}} = -90.48\text{MHz/V}$$

The phase detector relationship is given by:

$$K_\Phi = -|i_{ch}| \cdot K_V = 316.7\text{Hz}/\Omega$$

$i_{ch}$  is the current in tracking mode.

The loop bandwidth  $f_C$  should be chosen to fulfill the Gardner's stability criteria by at least a factor of 10, typical values are 50.  $\zeta = 0.9$  ensures a good transient response.

$$f_C < \frac{2 \cdot \zeta \cdot f_{ref}}{\pi \cdot (\zeta + \sqrt{1 + \zeta^2})} \cdot \frac{1}{10} \rightarrow f_C < \frac{f_{ref}}{4 \cdot 10}; (\zeta = 0.9)$$

$$f_C < 25\text{kHz}$$

And finally the frequency relationship is defined as

$$n = \frac{f_{VCO}}{f_{ref}} = 2 \cdot (\text{synr} + 1) = 50$$

With the above values the resistance can be calculated. The example is shown for a loop bandwidth  $f_C=10\text{kHz}$ :

$$R = \frac{2 \cdot \pi \cdot n \cdot f_C}{K_\Phi} = 2 \cdot \pi \cdot 50 \cdot 10\text{kHz} / (316.7\text{Hz}/\Omega) = 9.9\text{k}\Omega \approx 10\text{k}\Omega$$

The capacitance  $C_s$  can now be calculated as:

$$C_s = \frac{2 \cdot \zeta^2}{\pi \cdot f_C \cdot R} \approx \frac{0.516}{f_C \cdot R}; (\zeta = 0.9) = 5.19\text{nF} \approx 4.7\text{nF}$$

The capacitance  $C_p$  should be chosen in the range of:

$$C_s/20 \leq C_p \leq C_s/10 \quad C_p = 470\text{pF}$$

### B.6.3.2 Jitter Information

The basic functionality of the PLL is shown in **Figure B-3**. With each transition of the clock  $f_{cmp}$ , the deviation from the reference clock  $f_{ref}$  is measured and input voltage to the VCO is adjusted accordingly. The adjustment is done continuously with no abrupt changes in the clock output frequency. Noise, voltage, temperature and other factors cause slight variations in the control loop resulting in a clock jitter. This jitter affects the real minimum and maximum clock periods as illustrated in **Figure B-4**.

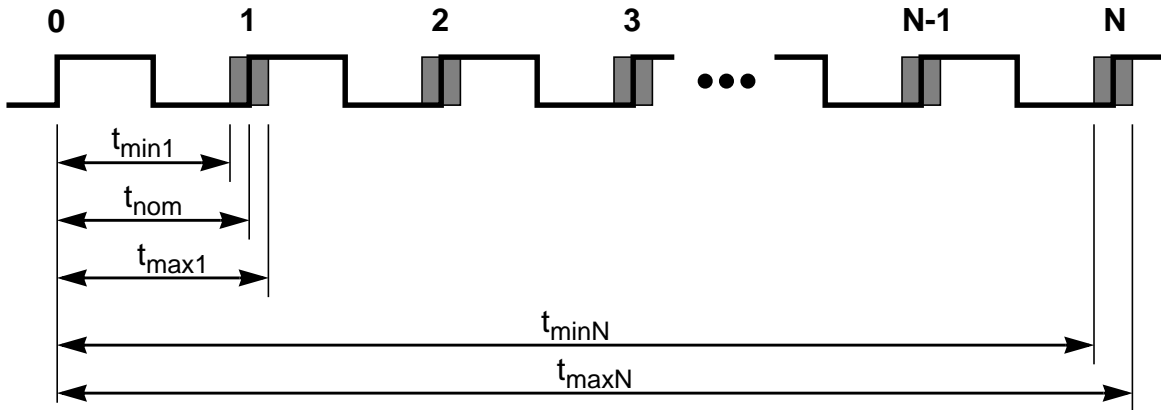

**Figure B-4 Jitter Definitions**

The relative deviation of  $t_{nom}$  is at its maximum for one clock period, and decreases towards zero for larger number of clock periods ( $N$ ).

Defining the jitter as:

$$J(N) = \max\left(\left|1 - \frac{t_{max}(N)}{N \cdot t_{nom}}\right|, \left|1 - \frac{t_{min}(N)}{N \cdot t_{nom}}\right|\right)$$

For  $N < 100$ , the following equation is a good fit for the maximum jitter:

$$J(N) = \frac{j_1}{\sqrt{N}} + j_2$$

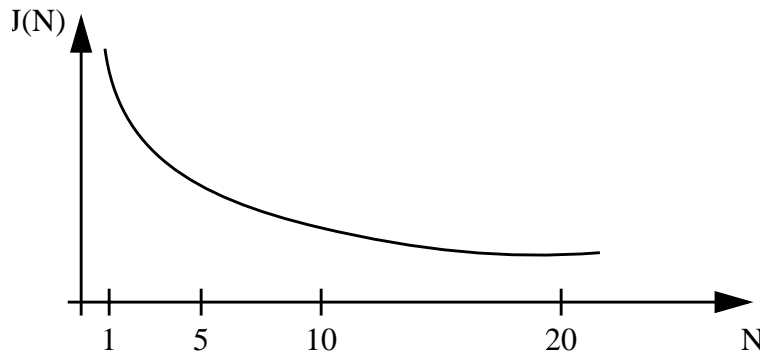

**Figure B-5 Maximum bus clock jitter approximation**

This is very important to notice with respect to timers, serial modules where a pre-scaler will eliminate the effect of the jitter to a large extent.

**Table B-12 PLL Characteristics**

Conditions are shown in Table A-4 unless otherwise noted							
Num	C	Rating	Symbol	Min	Typ	Max	Unit
1	P	Self Clock Mode frequency	$f_{SCM}$	1		5.5	MHz
2	D	VCO locking range	$f_{VCO}$	8		50	MHz
3	D	Lock Detector transition from Acquisition to Tracking mode	$ \Delta_{trk} $	3		4	% <sup>1</sup>
4	D	Lock Detection	$ \Delta_{Lock} $	0		1.5	% <sup>(1)</sup>
5	D	Un-Lock Detection	$ \Delta_{unt} $	0.5		2.5	% <sup>(1)</sup>
6	D	Lock Detector transition from Tracking to Acquisition mode	$ \Delta_{unt} $	6		8	% <sup>(1)</sup>
7	C	PLLON Total Stabilization delay (Auto Mode) <sup>2</sup>	$t_{stab}$		0.5		ms
8	D	PLLON Acquisition mode stabilization delay <sup>(2)</sup>	$t_{acq}$		0.3		ms
9	D	PLLON Tracking mode stabilization delay <sup>(2)</sup>	$t_{al}$		0.2		ms
10	D	Fitting parameter VCO loop gain	$K_1$		-100		MHz/V
11	D	Fitting parameter VCO loop frequency	$f_1$		60		MHz
12	D	Charge pump current acquisition mode	$ i_{ch} $		38.5		$\mu A$
13	D	Charge pump current tracking mode	$ i_{ch} $		3.5		$\mu A$
14	C	Jitter fit parameter 1 <sup>(2)</sup>	$j_1$			1.1	%
15	C	Jitter fit parameter 2 <sup>(2)</sup>	$j_2$			0.13	%

NOTES:

1. % deviation from target frequency
2.  $f_{OSC} = 4\text{MHz}$ ,  $f_{BUS} = 25\text{MHz}$  equivalent  $f_{VCO} = 50\text{MHz}$ : REFDV = #03, SYNRR = #018, Cs = 4.7nF, Cp = 470pF, Rs = 10K $\Omega$ .



## B.7 MSCAN

**Table B-13 MSCAN Wake-up Pulse Characteristics**

Conditions are shown in Table A-4 unless otherwise noted						
Num	C	Rating	Symbol	Min	Typ	Max
1	P	MSCAN Wake-up dominant pulse filtered	$t_{WUP}$			2
2	P	MSCAN Wake-up dominant pulse pass	$t_{WUP}$	5		



## B.8 SPI

# Appendix C Electrical Specifications

This section provides electrical parametrics and ratings for the SPI.

In **Table C-1** the measurement conditions are listed.

**Table C-1 Measurement Conditions**

Description	Value	Unit
Drive mode	full drive mode	—
Load capacitance $C_{LOAD}$ , on all outputs	50	pF
Thresholds for delay measurement points	(20% / 80%) VDDX	V

## C.1 Master Mode

In **Figure C-1** the timing diagram for master mode with transmission format CPHA=0 is depicted.

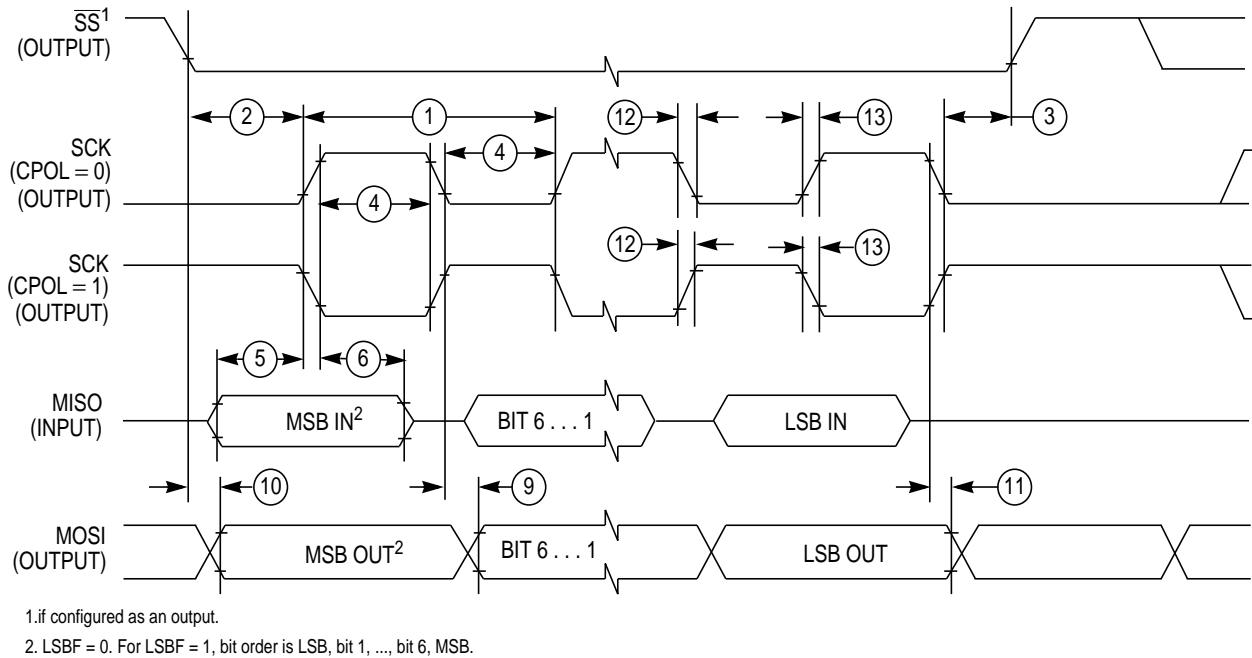

**Figure C-1 SPI Master Timing (CPHA=0)**

In **Figure C-2** the timing diagram for master mode with transmission format CPHA=1 is depicted.

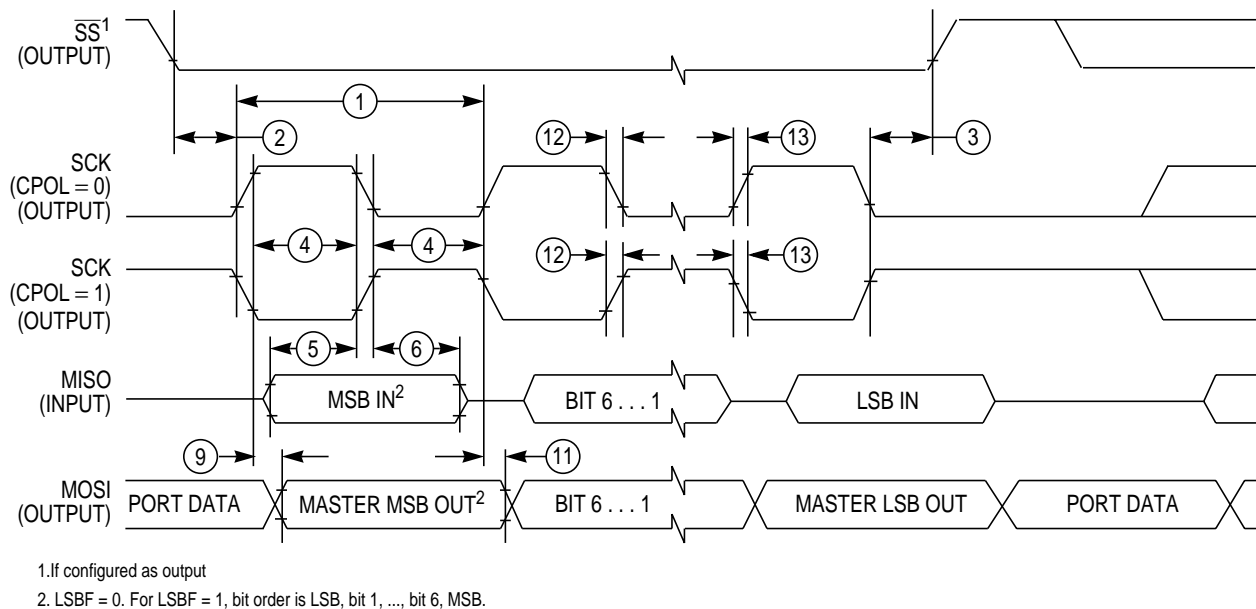

Figure C-2 SPI Master Timing (CPHA=1)

In Table C-2 the timing characteristics for master mode are listed.

Table C-2 SPI Master Mode Timing Characteristics

Num	C	Characteristic	Symbol	Min	Typ	Max	Unit
1	P	SCK Frequency	$f_{sck}$	1/2048	—	1/2	$f_{bus}$
1	P	SCK Period	$t_{sck}$	2	—	2048	$t_{bus}$
2	D	Enable Lead Time	$t_{lead}$	—	1/2	—	$t_{sck}$
3	D	Enable Lag Time	$t_{lag}$	—	1/2	—	$t_{sck}$
4	D	Clock (SCK) High or Low Time	$t_{wsck}$	—	1/2	—	$t_{sck}$
5	D	Data Setup Time (Inputs)	$t_{su}$	8	—	—	ns
6	D	Data Hold Time (Inputs)	$t_{hi}$	8	—	—	ns
9	D	Data Valid after SCK Edge	$t_{vsck}$	—	—	30	ns
10	D	Data Valid after $\overline{SS}$ fall (CPHA=0)	$t_{vss}$	—	—	15	ns
11	D	Data Hold Time (Outputs)	$t_{ho}$	20	—	—	ns
12	D	Rise and Fall Time Inputs	$t_{rfi}$	—	—	8	ns
13	D	Rise and Fall Time Outputs	$t_{rfo}$	—	—	8	ns

## C.2 Slave Mode

In **Figure C-3** the timing diagram for slave mode with transmission format CPHA=0 is depicted.

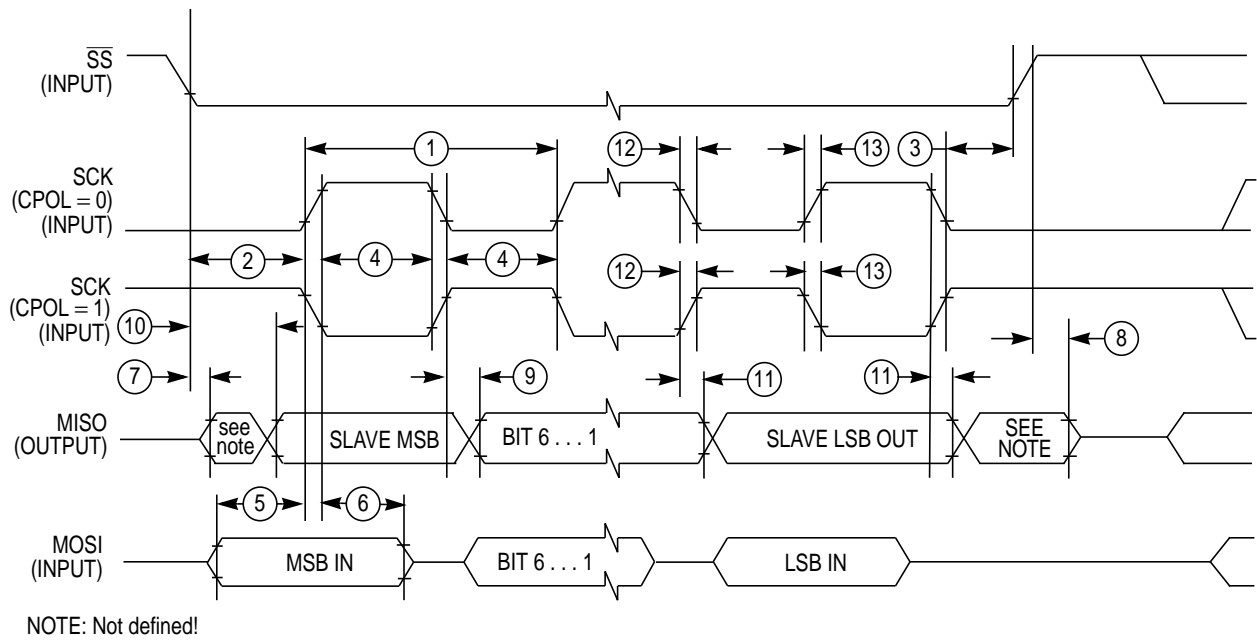

**Figure C-3 SPI Slave Timing (CPHA=0)**

In **Figure C-4** the timing diagram for slave mode with transmission format CPHA=1 is depicted.

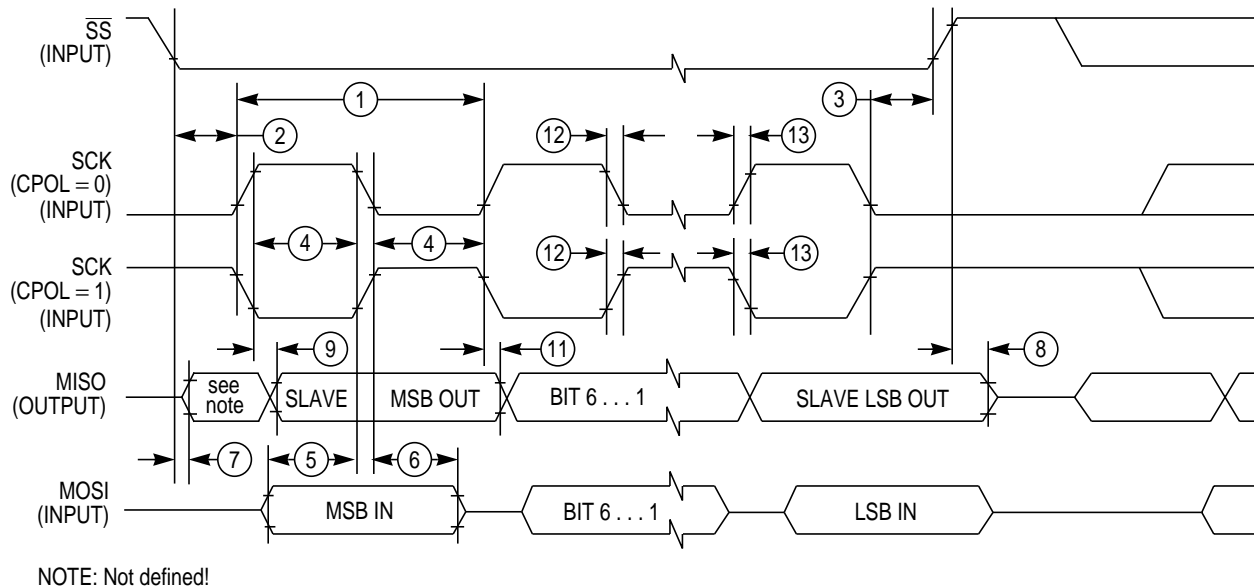

**Figure C-4 SPI Slave Timing (CPHA=1)**

In **Table C-3** the timing characteristics for slave mode are listed.

**Table C-3 SPI Slave Mode Timing Characteristics**

Num	C	Characteristic	Symbol	Min	Typ	Max	Unit
1	D	SCK Frequency	$f_{sck}$	DC	—	1/4	$f_{bus}$
1	P	SCK Period	$t_{sck}$	4	—	$\infty$	$t_{bus}$
2	D	Enable Lead Time	$t_{lead}$	4	—	—	$t_{bus}$
3	D	Enable Lag Time	$t_{lag}$	4	—	—	$t_{bus}$
4	D	Clock (SCK) High or Low Time	$t_{wsck}$	4	—	—	$t_{bus}$
5	D	Data Setup Time (Inputs)	$t_{su}$	8	—	—	ns
6	D	Data Hold Time (Inputs)	$t_{hi}$	8	—	—	ns
7	D	Slave Access Time (time to data active)	$t_a$	—	—	20	ns
8	D	Slave MISO Disable Time	$t_{dis}$	—	—	22	ns
9	D	Data Valid after SCK Edge	$t_{vsck}$	—	—	$30 + t_{bus}^1$	ns
10	D	Data Valid after $\overline{SS}$ fall	$t_{vss}$	—	—	$30 + t_{bus}^1$	ns
11	D	Data Hold Time (Outputs)	$t_{ho}$	20	—	—	ns
12	D	Rise and Fall Time Inputs	$t_{rfi}$	—	—	8	ns
13	D	Rise and Fall Time Outputs	$t_{rfo}$	—	—	8	ns

NOTES:

1.  $t_{bus}$  added due to internal synchronization delay

## C.3 External Bus Timing

A timing diagram of the external multiplexed-bus is illustrated in **Figure C-5** with the actual timing values shown on table Table C-4. All major bus signals are included in the diagram. While both a data write and data read cycle are shown, only one or the other would occur on a particular bus cycle.

### C.3.1 General Muxed Bus Timing

The expanded bus timings are highly dependent on the load conditions. The timing parameters shown assume a balanced load across all outputs.

**Figure C-5 General External Bus Timing**

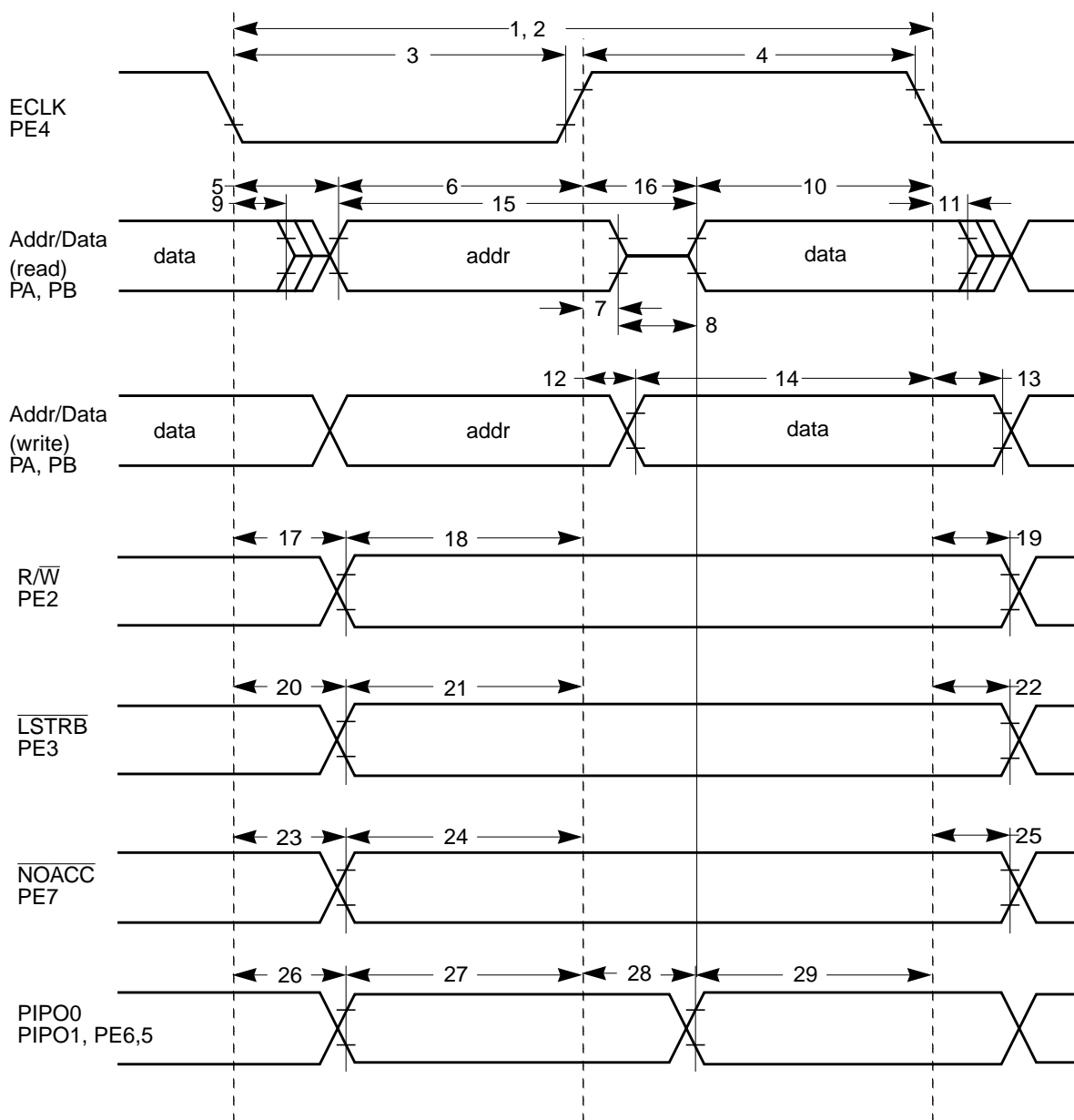

**Table C-4 Expanded Bus Timing Characteristics (5V Range)**

Conditions are 4.75V < VDDX < 5.25V, Junction Temperature -40°C to +140°C, C <sub>LOAD</sub> = 50pF							
Num	C	Rating	Symbol	Min	Typ	Max	Unit
1	P	Frequency of operation (E-clock)	f <sub>o</sub>	0		25.0	MHz
2	P	Cycle time	t <sub>cyc</sub>	40			ns
3	D	Pulse width, E low	PW <sub>EL</sub>	19			ns
4	D	Pulse width, E high <sup>1</sup>	PW <sub>EH</sub>	19			ns
5	D	Address delay time	t <sub>AD</sub>			8	ns
6	D	Address valid time to E rise (PW <sub>EL</sub> -t <sub>AD</sub> )	t <sub>AV</sub>	11			ns
7	D	Muxed address hold time	t <sub>MAH</sub>	2			ns
8	D	Address hold to data valid	t <sub>AHDS</sub>	7			ns
9	D	Data hold to address	t <sub>DHA</sub>	2			ns
10	D	Read data setup time	t <sub>DSR</sub>	13			ns
11	D	Read data hold time	t <sub>DHR</sub>	0			ns
12	D	Write data delay time	t <sub>DDW</sub>			7	ns
13	D	Write data hold time	t <sub>DHW</sub>	2			ns
14	D	Write data setup time <sup>(1)</sup> (PW <sub>EH</sub> -t <sub>DDW</sub> )	t <sub>DSW</sub>	12			ns
15	D	Address access time <sup>(1)</sup> (t <sub>cyc</sub> -t <sub>AD</sub> -t <sub>DSR</sub> )	t <sub>ACCA</sub>	19			ns
16	D	E high access time <sup>(1)</sup> (PW <sub>EH</sub> -t <sub>DSR</sub> )	t <sub>ACCE</sub>	6			ns
17	D	Read/write delay time	t <sub>RWD</sub>			7	ns
18	D	Read/write valid time to E rise (PW <sub>EL</sub> -t <sub>RWD</sub> )	t <sub>RWV</sub>	14			ns
19	D	Read/write hold time	t <sub>RWH</sub>	2			ns
20	D	Low strobe delay time	t <sub>LSD</sub>			7	ns
21	D	Low strobe valid time to E rise (PW <sub>EL</sub> -t <sub>LSD</sub> )	t <sub>LSV</sub>	14			ns
22	D	Low strobe hold time	t <sub>LSH</sub>	2			ns
23	D	NOACC strobe delay time	t <sub>NOD</sub>			7	ns
24	D	NOACC valid time to E rise (PW <sub>EL</sub> -t <sub>LSD</sub> )	t <sub>NOV</sub>	14			ns
25	D	NOACC hold time	t <sub>NOH</sub>	2			ns
26	D	IPIPO[1:0] delay time	t <sub>P0D</sub>	2		7	ns
27	D	IPIPO[1:0] valid time to E rise (PW <sub>EL</sub> -t <sub>P0D</sub> )	t <sub>P0V</sub>	11			ns
28	D	IPIPO[1:0] delay time <sup>(1)</sup> (PW <sub>EH</sub> -t <sub>P1V</sub> )	t <sub>P1D</sub>	2		25	ns
29	D	IPIPO[1:0] valid time to E fall	t <sub>P1V</sub>	11			ns

## NOTES:

1. Affected by clock stretch: add N x t<sub>cyc</sub> where N=0,1,2 or 3, depending on the number of clock stretches.

**Table C-5 Expanded Bus Timing Characteristics (3.3V Range)**Conditions are VDDX=3.3V+/-10%, Junction Temperature -40°C to +140°C, C<sub>LOAD</sub> = 50pF

Num	C	Rating	Symbol	Min	Typ	Max	Unit
1	D	Frequency of operation (E-clock)	$f_o$	0		16.0	MHz
2	D	Cycle time	$t_{cyc}$	62.5			ns
3	D	Pulse width, E low	PW <sub>EL</sub>	30			ns
4	D	Pulse width, E high <sup>1</sup>	PW <sub>EH</sub>	30			ns
5	D	Address delay time	$t_{AD}$			16	ns
6	D	Address valid time to E rise (PW <sub>EL</sub> - $t_{AD}$ )	$t_{AV}$	16			ns
7	D	Muxed address hold time	$t_{MAH}$	2			ns
8	D	Address hold to data valid	$t_{AHDS}$	7			ns
9	D	Data hold to address	$t_{DHA}$	2			ns
10	D	Read data setup time	$t_{DSR}$	15			ns
11	D	Read data hold time	$t_{DHR}$	0			ns
12	D	Write data delay time	$t_{DDW}$			15	ns
13	D	Write data hold time	$t_{DHW}$	2			ns
14	D	Write data setup time <sup>(1)</sup> (PW <sub>EH</sub> - $t_{DDW}$ )	$t_{DSW}$	15			ns
15	D	Address access time <sup>(1)</sup>	$t_{ACCA}$	29			ns
16	D	E high access time <sup>(1)</sup> (PW <sub>EH</sub> - $t_{DSR}$ )	$t_{ACCE}$	15			ns
17	D	Read/write delay time	$t_{RWD}$			14	ns
18	D	Read/write valid time to E rise (PW <sub>EL</sub> - $t_{RWD}$ )	$t_{RWV}$	16			ns
19	D	Read/write hold time	$t_{RWH}$	2			ns
20	D	Low strobe delay time	$t_{LSD}$			14	ns
21	D	Low strobe valid time to E rise (PW <sub>EL</sub> - $t_{LSD}$ )	$t_{LSV}$	16			ns
22	D	Low strobe hold time	$t_{LSH}$	2			ns
23	D	NOACC strobe delay time	$t_{NOD}$			14	ns
24	D	NOACC valid time to E rise (PW <sub>EL</sub> - $t_{LSD}$ )	$t_{NOV}$	16			ns
25	D	NOACC hold time	$t_{NOH}$	2			ns
26	D	IPIPO[1:0] delay time	$t_{POD}$	2		14	ns
27	D	IPIPO[1:0] valid time to E rise (PW <sub>EL</sub> - $t_{POD}$ )	$t_{POV}$	16			ns
28	D	IPIPO[1:0] delay time <sup>(1)</sup>	$t_{P1D}$	2		25	ns
29	D	IPIPO[1:0] valid time to E fall	$t_{P1V}$	11			ns

## NOTES:

1. Affected by clock stretch: add  $N \times t_{cyc}$  where  $N=0,1,2$  or  $3$ , depending on the number of clock stretches.



# Appendix D Package Information

## D.1 General

This section provides the physical dimensions of the MC9S12C Family and MC9S12GC Family packages 48LQFP, 52LQFP, 80QFP.

## D.2 80-pin QFP package

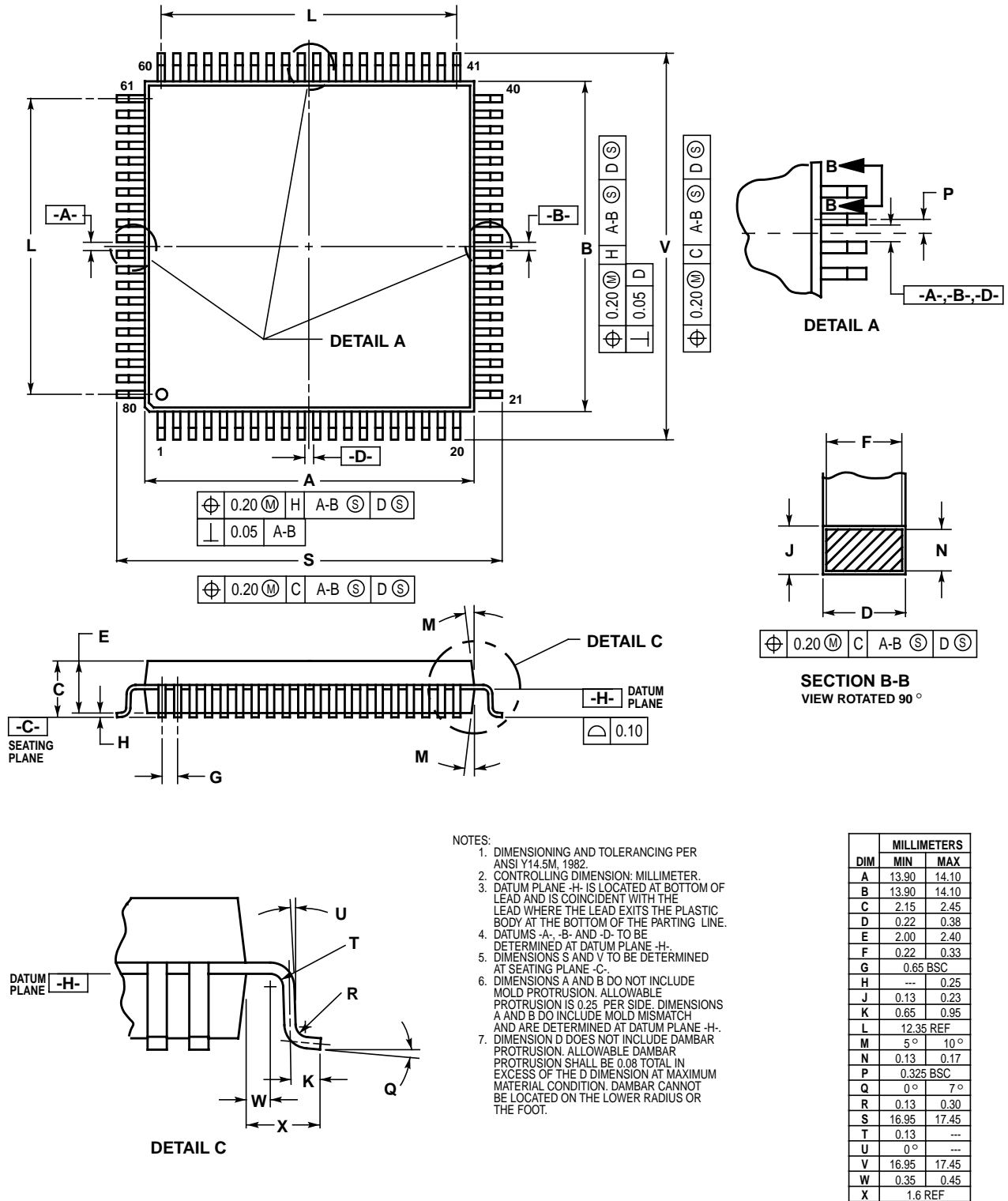

Figure D-1 80-pin QFP Mechanical Dimensions (case no. 841B)

### D.3 52-pin LQFP package

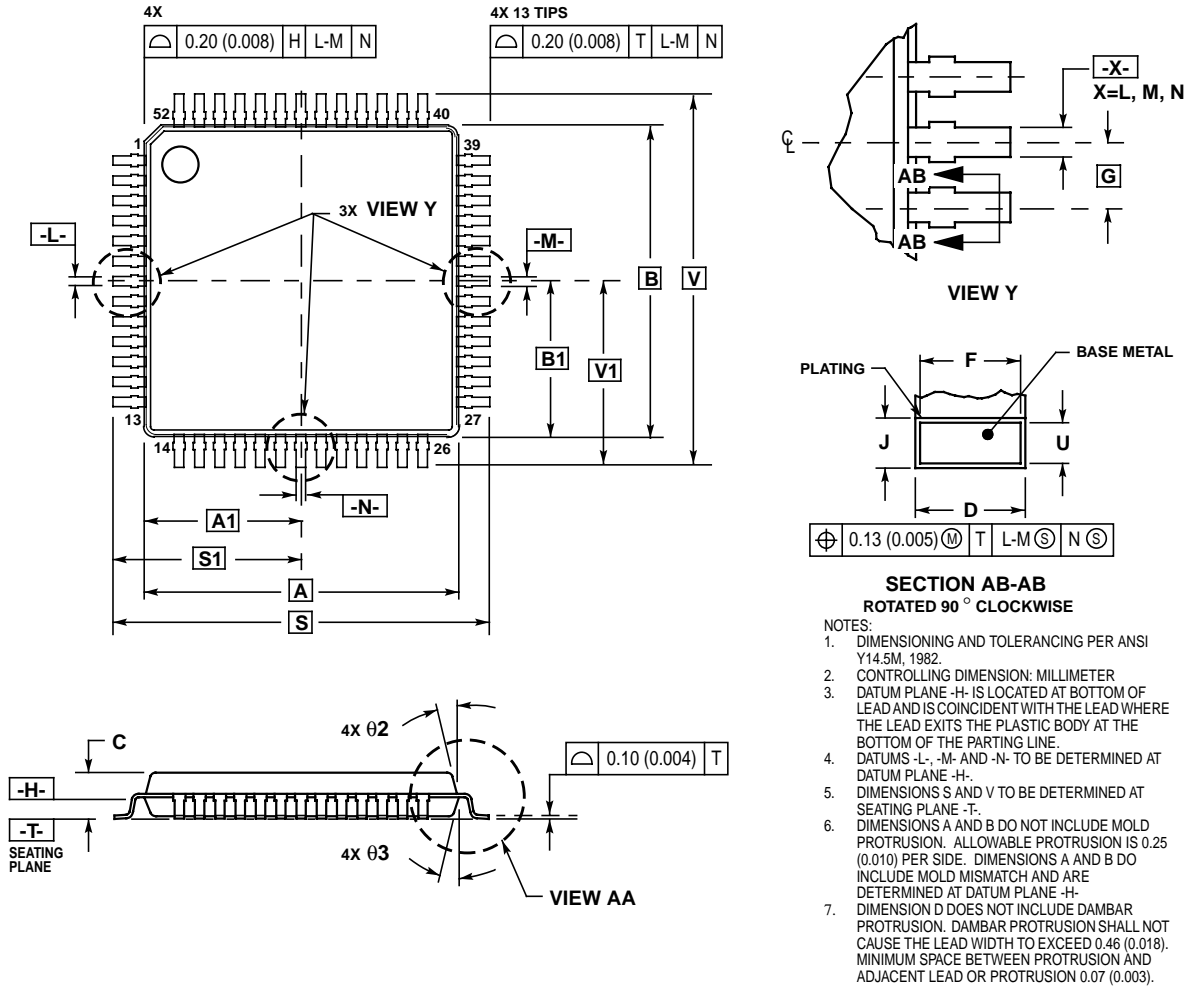

Figure D-2 52-pin LQFP Mechanical Dimensions (case no. 848D-03)

## D.4 48-pin LQFP package

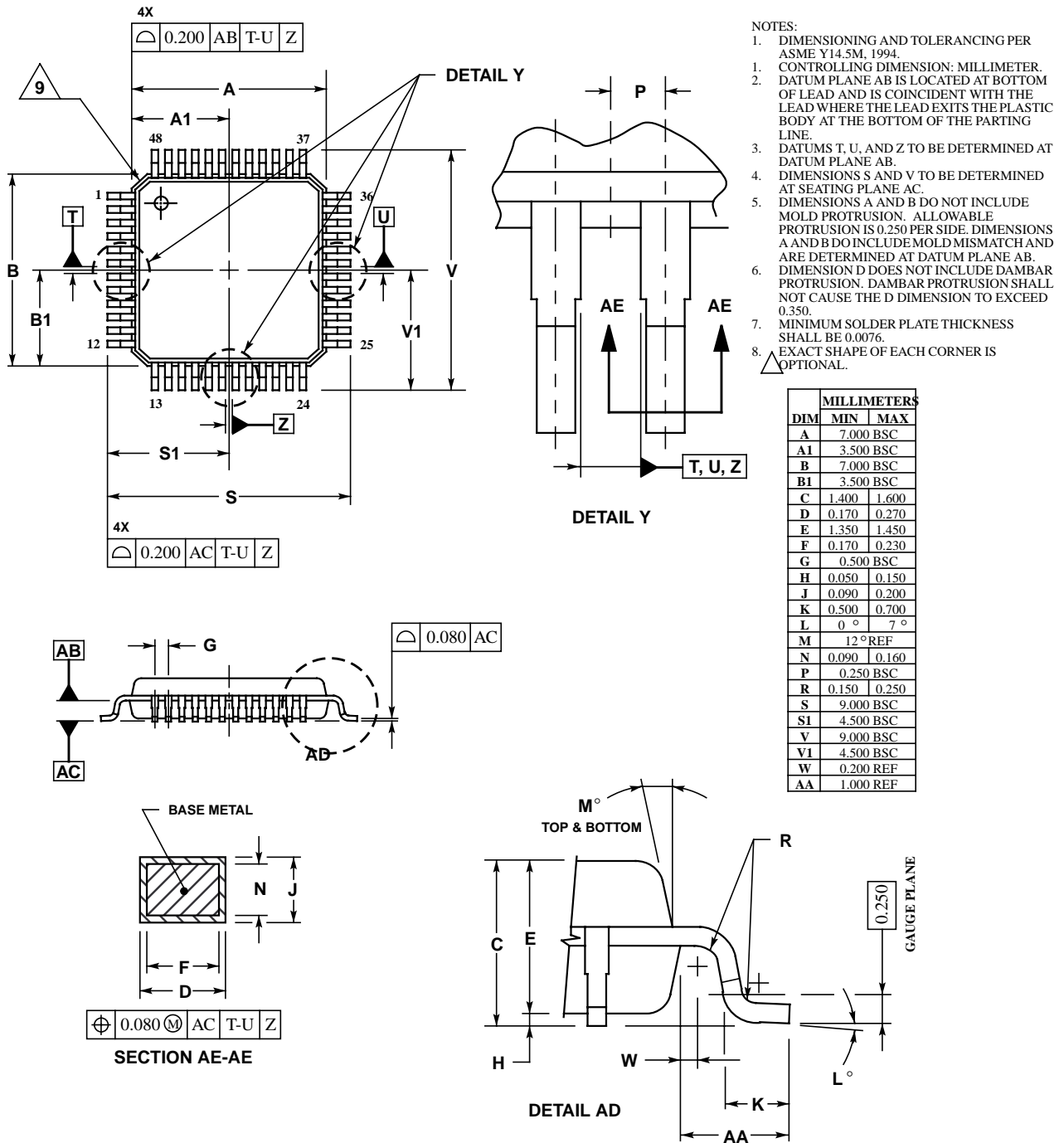
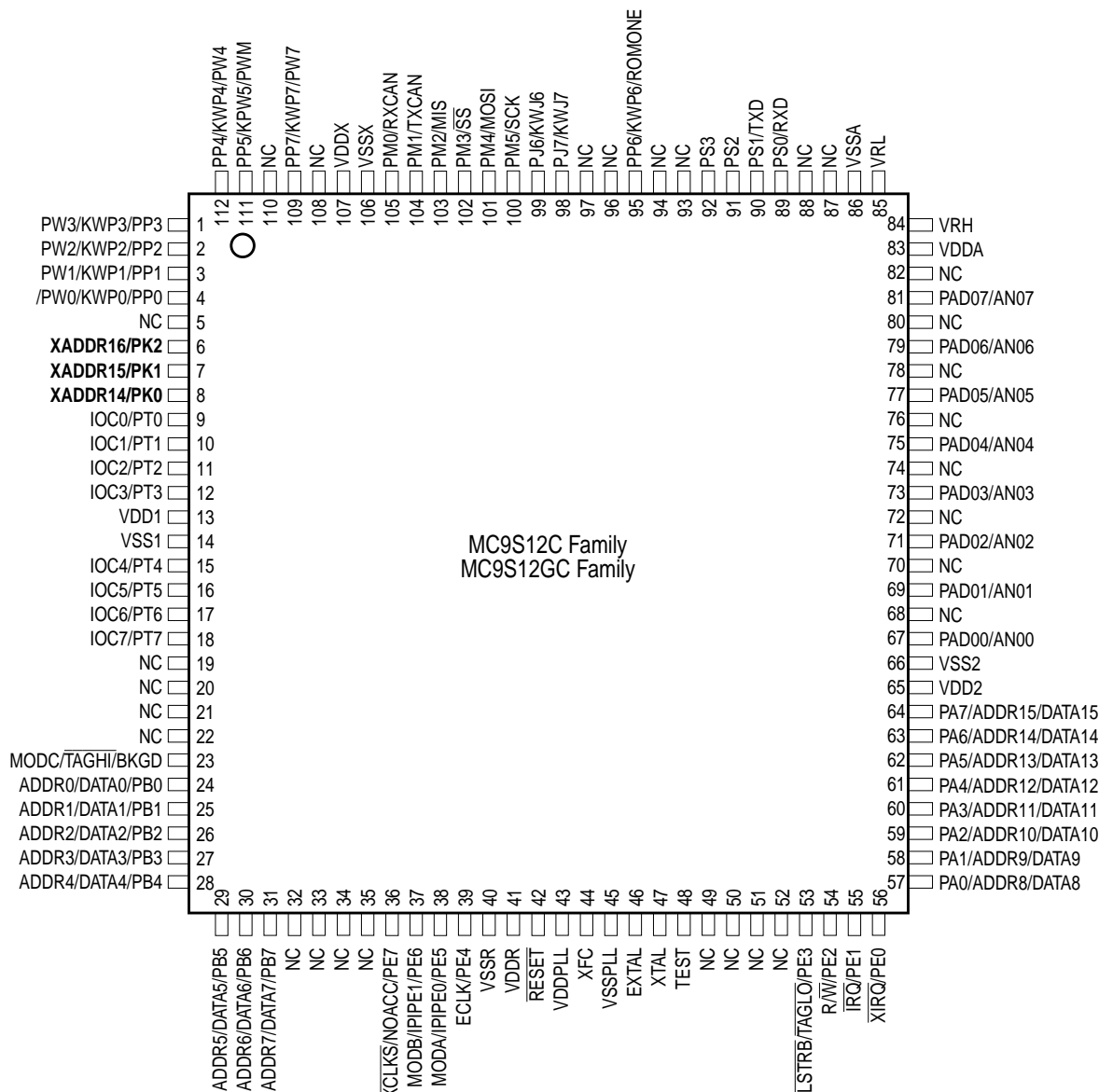

Figure D-3 48-pin LQFP Mechanical Dimensions (case no.932-03 ISSUE F)

# Appendix E Emulation Information

## E.1 General

In order to emulate the MC9S12C and 9S12GC-Family devices, external addressing of a 128K memory map is required. This is provided in a 112 LQFP package version which includes the 3 necessary extra external address bus signals via PortK. This package version is for emulation only and not provided as a general production package.



Signals shown in **Bold** are available only in the 112 Pin Package. Pins marked "NC" are not connected

**Figure 19-1 Pin Assignments in 112-pin LQFP**

### E.1.1 PK[2:0] / XADDR[16:14]

PK2-PK0 provide the expanded address XADDR[16:14] for the external bus.

Refer to the S12 Core user guide for detailed information about external address page access.

Pin Name Function 1	Pin Name Function 2	Power Domain	Internal Pull Resistor		Description
			CTRL	Reset State	
PK[2:0]	XADDR[16:14]	VDDX	PUPKE	Up	Port K I/O Pins

The reset state of DDRK in the S12\_CORE is \$00, configuring the pins as inputs.

The reset state of PUPKE in the PUCR register of the S12\_CORE is "1" enabling the internal pullup resistors at PortK[2:0].

In this reset state the pull-up resistors provide a defined state and prevent a floating input, thereby preventing unnecessary current consumption at the input stage.

## E.2 112-pin LQFP package

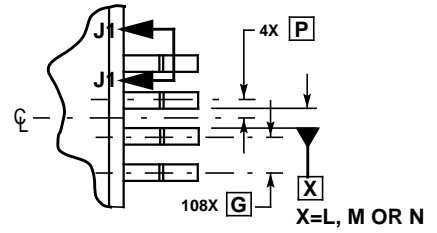
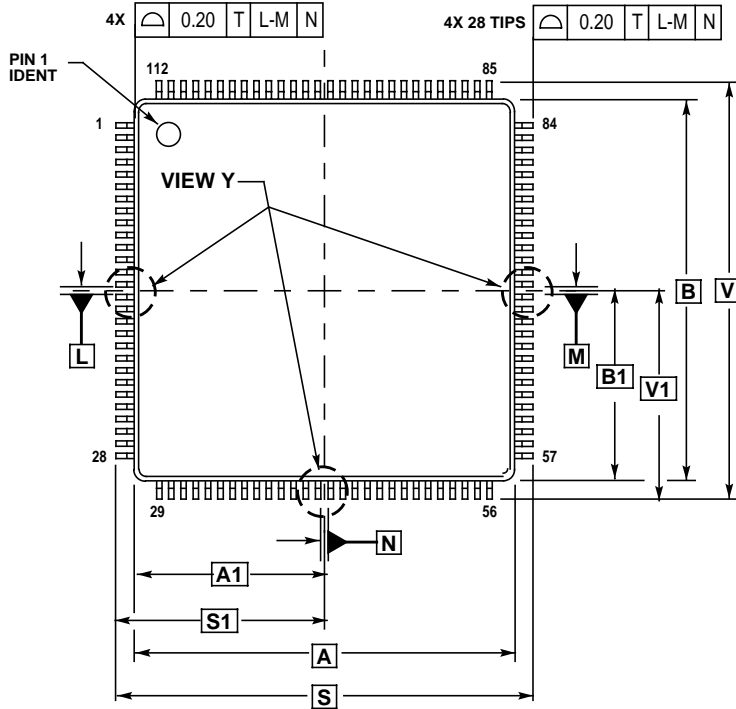

VIEW Y

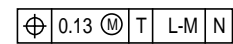
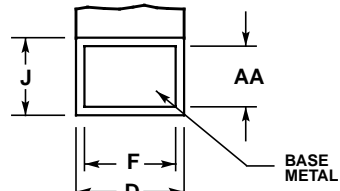

SECTION J1-J1  
ROTATED 90° COUNTERCLOCKWISE

NOTES:

1. DIMENSIONING AND TOLERANCING PER ASME Y14.5M, 1994.
2. DIMENSIONS IN MILLIMETERS.
3. DATUMS L, M AND N TO BE DETERMINED AT SEATING PLANE, DATUM T.
4. DIMENSIONS S AND V TO BE DETERMINED AT SEATING PLANE, DATUM T.
5. DIMENSIONS A AND B DO NOT INCLUDE MOLD PROTRUSION. ALLOWABLE PROTRUSION IS 0.25 PER SIDE. DIMENSIONS A AND B INCLUDE MOLD MISMATCH.
6. DIMENSION D DOES NOT INCLUDE DAMBAR PROTRUSION. ALLOWABLE DAMBAR PROTRUSION SHALL NOT CAUSE THE D DIMENSION TO EXCEED 0.46.

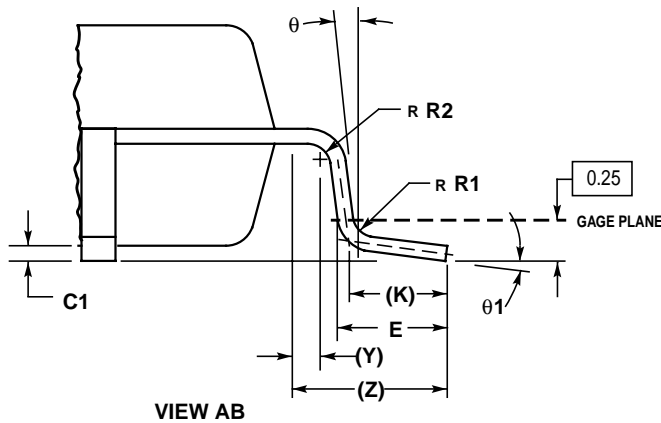
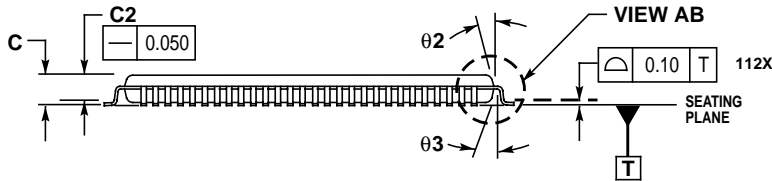

DIM	MILLIMETERS	
	MIN	MAX
A	20.000	BSC
A1	10.000	BSC
B	20.000	BSC
B1	10.000	BSC
C	---	1.600
C1	0.050	0.150
C2	1.350	1.450
D	0.270	0.370
E	0.450	0.750
F	0.270	0.330
G	0.650	BSC
J	0.090	0.170
K	0.500	REF
P	0.325	BSC
R1	0.100	0.200
R2	0.100	0.200
S	22.000	BSC
S1	11.000	BSC
V	22.000	BSC
V1	11.000	BSC
Y	0.250	REF
Z	1.000	REF
AA	0.090	0.160
theta	0°	8°
theta 1	3°	7°
theta 2	11°	13°
theta 3	11°	13°

Figure 19-2 112-pin LQFP mechanical dimensions (case no. 987)80-pin QFP Mechanical Dimensions (case no. 841B)



# Device User Guide End Sheet

**FINAL PAGE OF  
136  
PAGES**